

# Shark

## Shark Air Purifier 3-in-1 HC500/450 Series



	<b>Read and review instructions for operation and use.</b>
	<b>Indicates the presence of a hazard that can cause personal injury, death, or substantial property damage if the warning included with this symbol is ignored.</b>
	<b>For indoor and household use only.</b>

## OWNER'S GUIDE

### IMPORTANT SAFETY INSTRUCTIONS

When using electrical appliances, basic safety precautions should always be followed, including the following:  
**HOUSEHOLD USE ONLY**

#### WARNING

1. Read all instructions before use.
2. This appliance has a polarized plug (one blade is wider than the other). To reduce the risk of electric shock, this plug is intended to fit in a polarized outlet only one way. If the plug does not fit fully in the outlet, reverse the plug. If it still does not fit, contact a qualified electrician. **DO NOT** attempt to defeat this safety feature. Unplug or disconnect the appliance from the power supply before servicing.
3. **DO NOT** operate any appliance with a damaged cord or plug. Discard appliance or return to an authorized service facility for examination and/or repair.
4. **DO NOT** run cord under carpeting. **DO NOT** cover cord with throw rugs, runners, or similar coverings. **DO NOT** route cord under furniture or appliances. Keep cord away from high traffic areas and place cord where it will not be tripped over.
5. If the power cord is damaged, it must be replaced by the manufacturer, its service agent, or similarly qualified persons in order to avoid a hazard.
6. This appliance is not intended for use by anyone (including children) with reduced physical, sensory, or mental capabilities, or lack of experience and knowledge, unless they have been given supervision or instruction concerning use of the appliance by a person responsible for their safety.
7. Children should be supervised to ensure that they **DO NOT** play with the appliance.
8. Cleaning and user maintenance shall not be made by children without supervision.
9. Prior to cleaning or other maintenance, the appliance must be unplugged from the electrical outlet.
10. **DO NOT** handle plug or appliance with wet hands.
11. **DO NOT** use without filter in place.
12. Only use Shark® branded filters and accessories.
13. **DO NOT** damage the power cord:
  - a) **DO NOT** pull or carry appliance by the cord or use the cord as a handle.
  - b) **DO NOT** unplug by pulling on cord. Grasp the plug, not the cord.
  - c) **DO NOT** stand the appliance on the power cord, close a door on the cord, pull the cord around sharp corners, or leave the cord near heated surfaces.
14. **DO NOT** use with any opening blocked; keep free of dust, lint, hair, and anything that may reduce airflow.
15. **DO NOT** use if airflow is restricted. If the air paths become blocked, turn the appliance off and unplug from electrical outlet. Remove all obstructions before you plug in and turn on the unit again.
16. **DO NOT** use if appliance is not working as it should, or has been dropped, damaged, left outdoors, or dropped into water.
17. **DO NOT** place appliance on unstable surfaces such as chairs or other furniture.
18. **DO NOT** use in the following areas:
  - a) Wet or damp surfaces
  - b) Outdoor areas
  - c) Spaces that are enclosed and may contain explosive or toxic fumes or vapors (lighter fluid, gasoline, kerosene, paint, paint thinners, mothproofing substances, or flammable dust)

19. Turn off all controls before unplugging the appliance.
20. Unplug from electrical outlet when not in use and before any maintenance or cleaning.
21. Hand wash with soapy water only. Washing with cleaning chemicals could damage the unit.
22. Make sure filter is in place after routine maintenance.
23. Not suitable for use with solid-state speed controls.

#### IMPORTANT INSTRUCTIONS

24. This heater is hot when in use. To avoid burns, **DO NOT** let bare skin touch hot surfaces. If provided, use handles when moving this heater. Keep combustible materials, such as furniture, pillows, bedding, papers, clothes, and curtains at least 3 feet (0.9m) from the front of the heater and keep them away from the sides and rear.
25. Extreme caution is necessary when any heater is used by or near children or persons with disabilities and whenever the heater is left operating and unattended.
26. This heater is not intended for use in bathrooms, laundry areas, or other high moisture locations. Never locate heater where it may fall into a bathtub or other water container.
27. **DO NOT** insert or allow foreign objects to enter any ventilation or exhaust opening as this may cause an electric shock or fire, or damage the heater.
28. To prevent a possible fire, **DO NOT** block air intakes or exhaust in any manner. **DO NOT** use on soft surfaces, like a bed, where openings may become blocked.
29. A heater has hot, arcing and/or sparking parts inside. **DO NOT** use it in areas where gasoline, paint, or flammable liquids are used or stored.
30. Use this heater only as described in this manual. Any other use not recommended by the manufacturer may cause fire, electric shock, or injury to persons.
31. Always plug heaters directly into a wall outlet/receptacle. Never use with an extension cord or relocatable power tap (outlet/power strip).

#### WARNING: LITHIUM BATTERY

32. Dispose of coin cell batteries according to local regulations. Keep batteries away from children at all times. Even used batteries can cause injury.

#### **Chemical Burn Hazard. Keep batteries away from children.**

This product contains a lithium button/coin cell battery. If a new or used lithium button/coin cell battery is swallowed or enters the body, it can cause severe internal burns and can lead to death in as little as 2 hours. After changing batteries, always completely close and secure the battery compartment. If the battery compartment does not close securely, stop using the product, remove the battery, and keep it away from children. If you think battery might have been swallowed or placed inside any part of the body, seek immediate medical attention.

SCAN FOR  
ADDITIONAL  
RESOURCES



OR VISIT  
[qr.sharkclean.com/  
hc500series](http://qr.sharkclean.com/hc500series)

## SAVE THESE INSTRUCTIONS

## SETTING UP YOUR UNIT

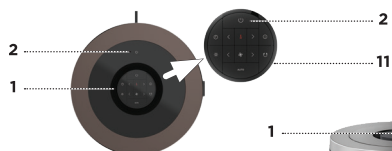

### Parts:

1. Remote Dock
2. Power Button
3. Front Vents
4. Air Angle Adjustment Tab
5. Mode Dial
6. Display
7. Unit Base
8. Back Vents
9. Shark NanoSeal™ HEPA Filter
10. Filter Door
11. Remote

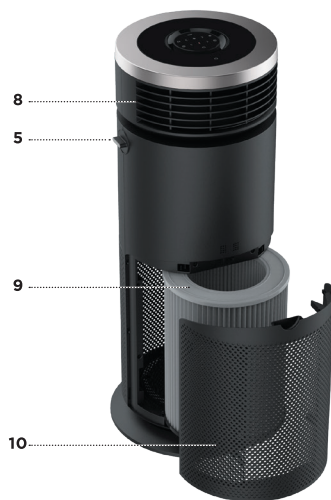

## TIPS FOR SETTING UP YOUR UNIT

- Orient the unit with display facing away from the wall.
- Do not move the unit while it is running. Turn off the power and unplug the unit before moving it.
- Make sure the vents are not blocked.
- Do not place anything on the appliance.
- Do not place the appliance near heaters or radiators.
- Keep the unit out of direct sunlight and away from water or other liquid.
- Keep all nearby doors and windows closed when operating the air purifier.
- Avoid using in very humid environments.

## SETTING UP YOUR AIR PURIFIER



1. You must remove the filter and take it out of its packaging before operating. First, remove the filter cover and filter from the **back of the air purifier**.



2. Take the filter out of its sealed plastic packaging. Slide filter back into the air purifier.



3. Reinstall the filter cover. Insert the tabs on the bottom of the cover into the slots. Press the top and sides of the cover until it clicks into place.



4. Set up the air purifier on a level floor surface at least 3 feet (0.9m) from the wall and any furnishings.

When carrying the air purifier, hold it below the venting area. **Do not** put your hands inside the vents

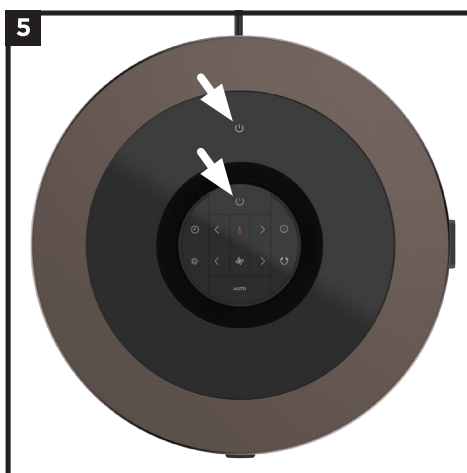

5. Plug the unit into an electrical outlet and press the power button on the top control panel **OR on the removable remote**.



6. When the air purifier is powered on, it will begin to analyze the air quality, indicated by the rotating lights.

After a few seconds, the air purifier will display the current air quality and room temperature. From there, use the remote and dial to customize the settings.

## REMOTE

You can use the **removable remote control** to customize the settings.

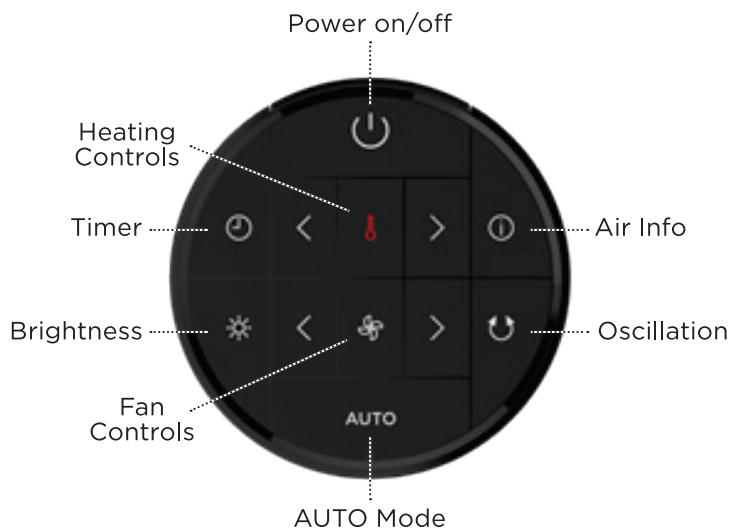

### REMOTE SHORTCUTS



**Turn Off Sound:** To turn off sounds, press and hold the Brightness button for 3 seconds.



**Turn On/Off Child Safety Lock:** Press and hold the Timer and Oscillation buttons to turn the Child Safety Lock on or off. The Lock icon will appear on the front display when the lock is activated.



**Change Temperature Display from Fahrenheit to Celsius:** Press and hold Fan and Thermometer buttons to change the temperature display from Fahrenheit to Celsius.

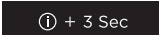

**Reset Filter Life:** Press and hold the info button for 3 seconds to reset the Filter Life display after changing the filter.

### REMOTE BUTTONS



**On/Off:** Press to turn the power on or off.



**AUTO mode:** Press to turn on AUTO mode. The fan speed automatically adjusts, based on the air quality. As the air quality improves, the fan speed will decrease. If air quality worsens, the fan speed will increase. **Leave your air purifier in AUTO mode for optimal filter life and performance. AUTO mode is only available in PURIFIED AIR mode.**

**Optimize Performance in ECO mode:** After the air is 100% clean for 10 minutes, the air purifier will enter ECO mode and will appear on the display. This reduces power draw and optimizes the filter life.



**Air Info:** Press to switch between air quality display options. See the Air Info Settings section for more information.



**Fan Controls:** Use the arrows to adjust the fan speed from 1-6. Press the fan button to view the speed setting. Fan speed can be adjusted in all 3 modes.

**Note:** When using AUTO mode, if fan speed is manually changed, AUTO mode will be deactivated. For tips on optimal fan setting, see Optimizing Fan Speed section.



**Heater Controls:** Press the Thermometer button to turn **HEAT** on/off. **Target Temperature:** Use the arrows to adjust the target temperature. The heater will automatically work to reach and maintain the target. The air purifier will beep when the target temperature is reached.

**HI HEAT Mode:** To run the heater in HI HEAT mode without selecting a target temperature, press and hold the right-side temperature arrow until HI appears on the display. For more tips on optimizing heater performance, see the **Heater Operation** section.



**Shut-Off Timer:** Set the number of hours for the air purifier to run before it automatically shuts off. Timer can be set from 1-12 hours.



**Brightness:** Press to dim the brightness of the display. Switch between 3 options: full brightness, partially dim, or fully dim.



**Oscillation:** Press to turn the oscillation on or off. When oscillating, the unit will rotate side to side to distribute airflow around the room.

## MODE DIAL

Turn the dial to change modes.

### 1. PURIFIED FAN

To operate **FAN** mode, turn the dial to the Fan icon. In this mode, **purified air will be directed out of the front vents.**

### 2. PURIFIED HEAT

To operate **HEAT** mode, turn the dial to the Air icon. Then **press the Thermometer icon button on remote. In this mode, purified, warm air will be directed out of the front vents.**



### 3. PURIFIED AIR

To operate **PURIFIED AIR** mode, turn the mode dial to the Air icon. In this mode, purified air will be diffused out the back vents. **This allows for continuous air purification without the breeze of a fan.**

**While the air will be purified in all modes, PURIFIED AIR mode boosts cleaning power.**

**PURIFIED AIR** mode is compatible with AUTO and ECO modes.

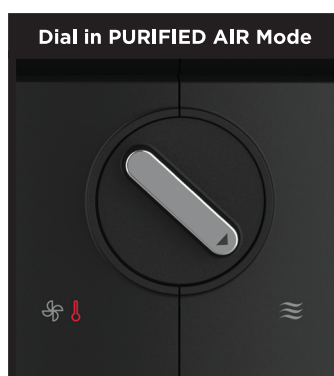

## MODE DISPLAYS

THE INFORMATION ON THE FRONT DISPLAY IS DIFFERENT IN EACH MODE.

### PURIFIED FAN

The top reading is the clean air percentage and the bottom reading is the current room temperature.



### PURIFIED HEAT

In this mode, the top reading is the clean air percentage and the bottom reading in red is the target temperature. Once the target temperature is reached, the bottom reading will display the current room temperature in white.



### PURIFIED AIR

In this mode, the percentage of clean air is shown.



The red thermometer light indicates that **the heater is on and warming to reach the target temperature.**



## UNDERSTANDING YOUR AIR QUALITY

The ring around the display will change color as the air quality changes, for easy monitoring from far away.

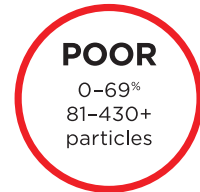
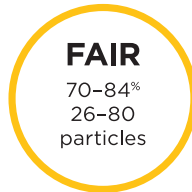
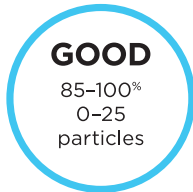

To improve **FAIR** or **POOR** air quality increase the fan speed or select AUTO mode.

**Note:** The air quality sensor uses a cumulative particle count across all particle sizes to determine percentage of clean air.

## AIR INFO SETTINGS

The built-in sensor detects your air quality to give you real-time information. Use the **AIR INFO** button ⓘ to switch between settings.

INFO	REAL-TIME READING
% CLEAN AIR	Displays the air quality rating: • <b>Poor: 0%-69%</b> • <b>Fair: 70%-84%</b> • <b>Good: 85%-100%</b> % CLEAN AIR uses particulate matter (PM) Air Quality Standards as determined by the EPA to calculate the air quality rating.
TIME TO CLEAN	Shows the estimated time remaining until your air is clean.
PARTICLE SIZES	<b>The PM (particulate matter) value is the amount of particulate in your air, measured in micrograms (µg) per cubic meter. Your air purifier measures three particle sizes, PM1, PM2.5, and PM10.</b>
PM1 🦠	Displays the amount of PM1-sized particles in your air, including viruses and ultra-fine allergens.
PM2.5 🔍	Displays the amount of PM2.5-sized particles in your air, including smoke and bacteria.
PM10 🌿	Displays the amount of PM10-sized particles in your air, including dust, mold, and pollen.
ROOM TEMPERATURE	Displays the current temperature in the room. *Only visible in PURIFIED AIR mode
FILTER LIFE	Displays the remaining filter life, as a percentage.



## AIR PURIFIER OPERATION

### TO ACTIVATE PURIFIED AIR MODE AND ADJUST SETTINGS:

1. Turn the mode dial to the Air icon.
2. The display will show air quality as a percentage. Press ⓘ the info button to change the air information displayed.
3. Press the fan arrows to adjust the fan speed. As fan speed increases, so will purification performance.
4. To activate AUTO mode, press the AUTO button. In this mode, the fan speed will automatically adjust, based on the quality of the air. **AUTO mode is only available in PURIFIED AIR mode.**
5. When in AUTO mode, if the air is 100% clean for 10 minutes, the air purifier will enter **ECO mode** and 🌱 will appear on the display. This will reduce energy consumption and extend the filter life.

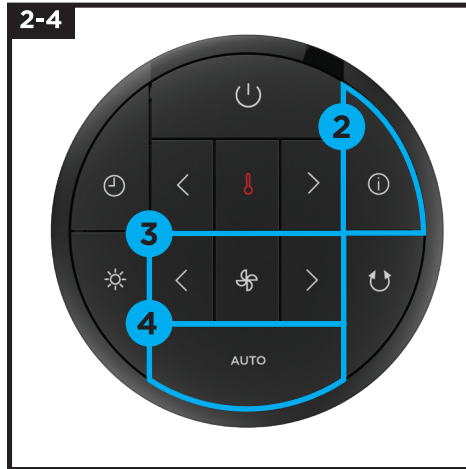

### TIPS FOR USING PURIFIED AIR MODE:

Air quality fluctuates, depending on what is introduced in the home. Some factors that can affect the air quality:

- Cooking or burning food
- Smoking
- Vacuuming or dusting
- Opening windows or exterior doors can introduce pollen.
- Spraying cleaning products

Leave the air purifier in AUTO mode for optimal filter life and performance.

**AUTO mode is ONLY available in PURIFIED AIR mode.**

## FAN OPERATION

### TO ACTIVATE THE FAN AND ADJUST AIRFLOW:

1. Turn the mode dial to the Fan icon.
2. On the front display, the top number is the clean air percentage and the bottom number is the current room temperature. Press ⓘ the Info button to change the air information displayed.
3. Press the fan arrows to adjust the fan speed or press the 🌀 Fan button to check current fan speed. As fan speed increases, so will purification performance.
4. Press the 🔄 Oscillation button on the remote to turn oscillation on or off.
5. Additionally, the airflow angle can be adjusted by moving the front vents up or down.

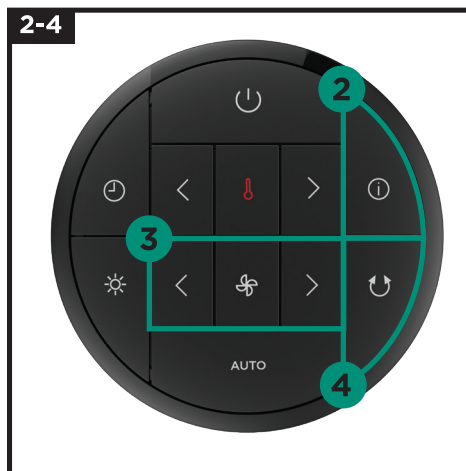

## NIGHT USE

For non-disruptive performance at night:

- Lower the fan speed for soothing white noise.
- Press the 🌞 Brightness button to fully dim the display.
- Turn on oscillation for better fan coverage.
- Press and hold the 🌞 Brightness button for 3 seconds to turn sound off or on.

## HEATER OPERATION

### TO ACTIVATE THE HEATER AND ADJUST SETTINGS:

1. Turn the mode dial to the Heat icon and press  to turn on heat.
2. On the front display, the top number is the clean air percentage. The bottom number in red is the target temperature.
3. Press the temperature arrows to set the target temperature or hold down the right arrow for HI heat mode. **When the target temperature is set, the display will flash and beep twice to confirm.**

**Note:** The heater may need up to 25 seconds to fully warm up. This will be indicated by the red 'heating up' animation.

4. After the target temperature is set and the heater is active, **the bottom number in the display will turn white and will update to show current room temperature.**
5. When the target temperature is reached, there will be a long beep, and heating will pause.
6. Use the fan arrows to adjust the heated air flow rate.
7. Press the Info  button to change the air information display.
8. Press the Oscillation icon to turn oscillation on or off.
9. Additionally, the airflow angle can be adjusted by moving the front vents up or down.

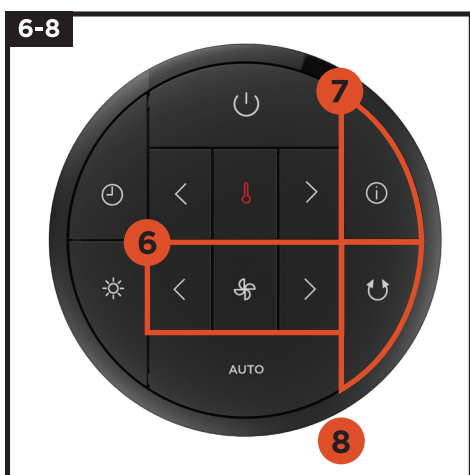

### TIPS FOR USING PURIFIED HEAT MODE

- When using the air purifier at close range for personal heating, lower the fan speed for optimal performance.
- When using the air purifier at a distance for whole-room heating, increase the fan speed and turn on oscillation for optimal performance.
- In HI heat mode, the heater will not have a temperature target and will continue to run until turned off.

### HEATER SAFETY FUNCTION AND RESET

The air purifier has multiple safety features designed to prevent overheating, accidents, and damage.

#### TIP-OVER AUTOMATIC SHUTOFF

If your air purifier gets tipped over, it will automatically turn off. Follow these steps to reactivate the heater:

1. Turn the power off and unplug the air purifier.
2. Set the air purifier upright, on a level floor surface.
3. Plug in the air purifier and turn on power.
4. Turn the mode dial to the Heat icon and press  to turn on heat.

#### OVERHEAT AUTOMATIC SHUTOFF

Your air purifier could overheat if obstructions block the vents. If this happens, the unit will automatically turn off. Follow these steps to reactivate the heater:

1. Turn the power off and unplug the air purifier.
2. Remove any obstructions from the vents.
3. Wait 5 minutes, then plug in the air purifier and turn on power.
4. Turn the mode dial to the Heat icon and press  to turn on heat.

**Note:** Any rattling heard when moving the air purifier may be caused by the internal safety tilt switch.



## INSTALLING AND REMOVING THE FILTER

**NOTE: Always remove all protective packaging from the filter before installing.**

Shark® filters are engineered to last between 6-12 months. When the filter life has 0% remaining, FILTER LIFE will illuminate and flash, indicating that it's time to install a new filter.

1. Turn off and unplug the air purifier before removing or installing filters.
2. First, remove the filter cover from the back of the air purifier. Use the handle to pull the filter door towards you.
3. To remove the old filter, pull it out by the removal tabs. Discard old filter in trash.
4. Remove all packaging and wrapping from the new filter.
5. Insert the new filter, then replace the filter cover. Insert the tabs on the bottom of the cover into the slots. Press the top and sides of the cover until it clicks into place.
6. Plug the air purifier back on and turn on power. Calibration will begin.
7. After installing a new filter, press and hold the ⓘ Info button for 3 seconds to reset the filter life percentage. The air purifier will beep to confirm when the filter life is reset to 100%.

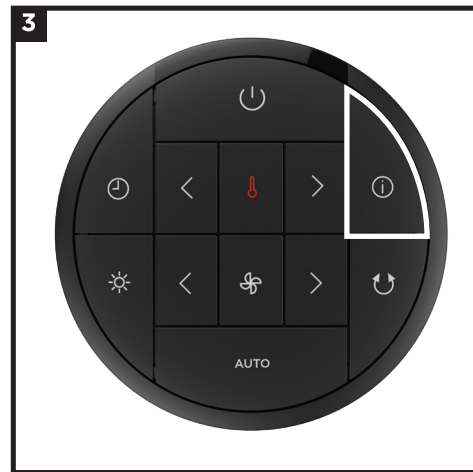

### Disposing of used filters

Filters can't be cleaned or recycled. After removing a used filter, wrap it in an airtight plastic bag for disposal. As an extra precaution, wear gloves when handling a dirty filter.

**To maximize filter life,** every three months, remove the filter, then turn it upside down and reinstall it. This will help equalize and balance the distribution of captured particles throughout the filter, allowing for extended use.

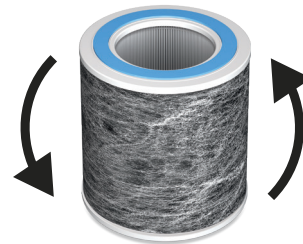

## MAINTAINING YOUR AIR PURIFIER

**NOTE: Always unplug the unit before doing any cleaning or maintenance.**

### Exterior Cleaning:

For best results, clean the exterior of the air purifier every two months or as needed. Use a microfiber cloth to remove dust. To sanitize, wipe down the exterior with a microfiber cloth dampened with warm, soapy water. Avoid excess water and abrasive chemical cleaners to prevent damage.



### Interior Cleaning:

For best results, clean the interior of the unit every two months or as needed. Remove the filter cover, take out the filter, and use a vacuum cleaner or a microfiber cloth to remove dust and debris from the interior of the air purifier. **DO NOT** use abrasive chemical cleaners on the inside of the air purifier.





## REPLACING THE REMOTE BATTERY

The removable remote is equipped with a CR2025 lithium coin cell battery with a life of up to 3 years. Periodically, the remote battery will require replacement.

1. Remove the remote from its dock on the top of the air purifier.
2. Pinch the tab on the battery compartment, then slide out the compartment.
3. Remove the battery and dispose of it immediately. Keep the battery away from children and pets.
4. Insert a new battery, (+) side facing up. Then slide the battery compartment back into the remote, until it clicks into place.
5. Point the remote at the air purifier and adjust the settings to ensure the remote is functioning properly. If there are persisting issues with the remote, see the Troubleshooting section.



## AVAILABLE ACCESSORIES

### ORDER ADDITIONAL ACCESSORIES AND REPLACEMENT FILTERS

from [sharkaccessories.com](http://sharkaccessories.com)

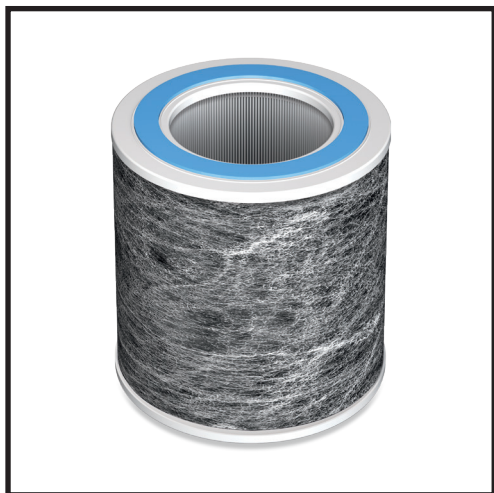

#### SHARK® NANOSEAL™ BASE FILTER WITH TRUE HEPA

Captures 99.98% of large, small, and micro-sized particles from the air and is equipped with carbon for heightened protection against household odors and VOCs.

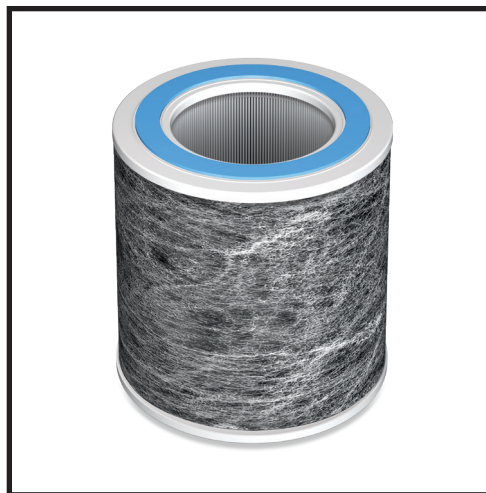

#### SHARK® NANOSEAL™ BASE FILTER WITH TRUE HEPA + MICROBAN

Captures 99.98% of large, small, and micro-sized particles from the air and is equipped with carbon for heightened protection against household odors and VOCs.

#### TREATED WITH MICROBAN:



Additional antimicrobial protection with Microban treatment. Microban reduces the bacterial growth on the HEPA surface.





SHARK® HC500/450 SERIES REMOTE CONTROL.

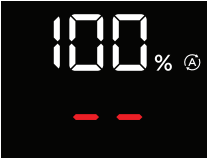
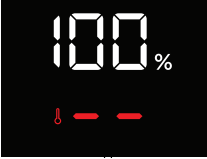

## TROUBLESHOOTING

ERROR CODE	MEANING	SOLUTION
	AUTO mode is not available in Purified Heat or Fan mode.	<ul style="list-style-type: none"> <li>• Make sure the mode dial on the side of the air purifier is pointing to the Air icon.</li> <li>• Then press AUTO on the remote to activate AUTO mode.</li> </ul>
	The heater is not active <b>OR</b> purified heat is not available in this mode.	<ul style="list-style-type: none"> <li>• Make sure the mode dial on the side of the air purifier is pointing to the Heat  icon.</li> <li>• Then press  on the remote to turn on PURIFIED HEAT mode.</li> </ul>

PROBLEM	SOLUTION
<b>My air purifier is not powering on, what should I do?</b>	<ul style="list-style-type: none"> <li>• Make sure the air purifier is set up on a flat, level floor surface. Plug it in and ensure that the outlet works. Press the power button to turn the air purifier on.</li> <li>• Make sure the filter cover is properly installed in the back of the air purifier. Insert the tabs on the bottom of the cover into the slots. Press the top and sides of the cover until it clicks into place.</li> <li>• Make sure filter is installed fully in the unit. Push filter into the unit firmly until the filter cannot be pushed back any more.</li> </ul>
<b>I can't feel air blowing out of the front of the air purifier.</b>	<ul style="list-style-type: none"> <li>• For PURIFIED FAN mode, make sure the mode dial on the side of the air purifier is pointing to the Fan icon. This will direct air out of the front vents.</li> <li>• For PURIFIED AIR mode, make sure the mode dial on the side of the air purifier is pointing to the Air icon. This will direct air out of the back vents.</li> <li>• Make sure the filter has been removed from its packaging.</li> </ul>
<b>How do I know when my air purifier is in AUTO mode?</b>	<ul style="list-style-type: none"> <li>• The  icon on the display illuminates when the air purifier is in AUTO mode. AUTO mode is ONLY available in PURIFIED AIR mode.</li> <li>• For PURIFIED AIR mode, make sure the mode dial on the side of the air purifier is pointing to the Air icon.</li> </ul>
<b>I can't turn the heater on.</b>	<ul style="list-style-type: none"> <li>• Make sure the mode dial on the side of the air purifier is pointing to the Heat icon.</li> <li>• Press the Heat icon on the remote to turn on PURIFIED HEAT mode.</li> </ul>
<b>My heater turned off on its own.</b>	<ul style="list-style-type: none"> <li>• Once a target temperature is set, the heater will work to achieve it. After the target is reached, the heater will monitor the temperature in the room and turn back on if the room temperature falls below the target.</li> <li>• The heater has built-in safety features designed to prevent overheating, accidents, and damage. If your heater has malfunctioned, follow the steps in the Heater Safety Function and Reset section.</li> </ul>
<b>How do I change the temperature display from Fahrenheit to Celsius?</b>	<ul style="list-style-type: none"> <li>• Simultaneously press and hold Fan and Thermometer buttons to change the temperature measurement display from Fahrenheit to Celsius.</li> </ul> <div style="text-align: center;">  +  = F → C                 </div>
<b>Why does my air smell bad?</b>	<ul style="list-style-type: none"> <li>• Make sure the filter has been removed from its packaging.</li> <li>• If your air purifier is brand new, there may be an initial electronic smell that will go away on its own.</li> <li>• If there have been odors in the area recently, such as from cigarettes or food, allow more time for the air purifier to remove them.</li> <li>• Clean off any dust or debris from the intake vent and air vent areas.</li> <li>• The filter may need to be replaced.</li> </ul>
<b>Can I wash the filter?</b>	<ul style="list-style-type: none"> <li>• No, the filter is not washable. Keep filter away from water and dispose of it when it is dirty.</li> </ul>
<b>How do I turn off the beeping?</b>	<ul style="list-style-type: none"> <li>• To turn sound on or off, press and hold the Brightness button for three seconds.</li> </ul>
<b>Why is my air purifier vibrating or making unusual loud noises?</b>	<ul style="list-style-type: none"> <li>• Make sure the air purifier is set up on its base and on a flat, level space on the floor.</li> </ul>
<b>My remote is not working.</b>	<ul style="list-style-type: none"> <li>• Make sure the Child Safety Lock is not activated, indicated by the Lock icon on the display.</li> <li>• To turn on/off Child Lock, simultaneously press and hold the Timer and Oscillation buttons.</li> <li>• Try replacing the remote battery. For instructions, see 'Replacing the Remote Battery' section.</li> </ul>

### Customer Service

For further assistance, call 1-855-523-4061.

## TWO (2) YEAR LIMITED WARRANTY

The Two (2) Year Limited Warranty applies to purchases made from authorized retailers of **SharkNinja Operating LLC**. Warranty coverage applies to the original owner and to the original product only and is not transferable.

SharkNinja warrants that the unit shall be free from defects in material and workmanship for a period of two (2) years from the date of purchase when it is used under normal household conditions and maintained according to the requirements outlined in the Owner's Guide, subject to the following conditions and exclusions:

### What is covered by this warranty?

1. The original air purifier and/or non-wearable parts deemed defective, in SharkNinja's sole discretion, will be repaired or replaced up to two (2) years from the original purchase date.
2. In the event a replacement unit is issued, the warranty coverage ends six (6) months following the receipt date of the replacement unit or the remainder of the existing warranty, whichever is later. SharkNinja reserves the right to replace the unit with one of equal or greater value.

### What is not covered by this warranty?

1. Normal wear and tear of wearable parts (such as filters and batteries, etc.), which require regular maintenance and/or replacement to ensure the proper functioning of your unit, are not covered by this warranty. Replacement parts are available for purchase at [sharkaccessories.com](http://sharkaccessories.com).
2. Any air purifier that has been tampered with or used for commercial purposes.
3. Damage caused by misuse, abuse, negligent handling, failure to perform required maintenance (e.g., not replacing the filters), or damage due to mishandling in transit.
4. Consequential and incidental damages.

5. Defects caused by repair persons not authorized by SharkNinja. These defects include damages caused in the process of shipping, altering, or repairing the SharkNinja product (or any of its parts) when the repair is performed by a repair person not authorized by SharkNinja.
6. Products purchased, used, or operated outside North America.

### How to get service

If your air purifier fails to operate properly while in use under normal household conditions within the warranty period, visit [sharkclean.com/support](http://sharkclean.com/support) for product care and maintenance self-help. Our Customer Service Specialists are also available at **1-855-523-4061** to assist with product support and warranty service options, including the possibility of upgrading to our VIP warranty service options for select product categories. So we may better assist you, please register your product online at [registryourshark.com](http://registryourshark.com) and have the product on hand when you call.

SharkNinja will cover the cost for the customer to send in the unit to us for repair or replacement. A fee of \$25.95 (subject to change) will be charged when SharkNinja ships the repaired or replacement unit.

### How to initiate a warranty claim

You must call **1-855-523-4061** to initiate a warranty claim. You will need the receipt as proof of purchase. We also ask that you register your product online at [registryourshark.com](http://registryourshark.com) and have the product on hand when you call, so we may better assist you. A Customer Service Specialist will provide you with return and packing instruction information.

### How state law applies

This warranty gives you specific legal rights, and you also may have other rights that vary from state to state. Some states do not permit the exclusion or limitation of incidental or consequential damages, so the above may not apply to you.

## IMPORTANT INFORMATION

### REGISTER YOUR PURCHASE



[registryourshark.com](http://registryourshark.com)



Scan QR code using mobile device



### RECORD THIS INFORMATION

Model Number: \_\_\_\_\_

Serial Number: \_\_\_\_\_

Date of Purchase: \_\_\_\_\_  
(Keep receipt)

Store of Purchase: \_\_\_\_\_

### TECHNICAL SPECIFICATIONS

Voltage: 120V~ 60Hz

Watts: 1500W

Benefits of registering your product and creating an account:

- Get easier, faster product support and access to warranty information
- Access troubleshooting and product care instructions
- Be among the first to know about exclusive product promotions

**TIP:** You can find the model and serial numbers on the QR code label on the bottom of the unit.

### PLEASE READ CAREFULLY AND KEEP FOR FUTURE REFERENCE.

This Owner's Guide is designed to help you get a complete understanding of your new Shark® Air Purifier.

SharkNinja Operating LLC  
US: Needham, MA 02494  
CAN: Ville St-Laurent, QC H4S 1A7  
1-800-798-7398  
[sharkclean.com](http://sharkclean.com)

Illustrations may differ from actual product. We are constantly striving to improve our products; therefore the specifications contained herein are subject to change without notice.

This product may be covered by one or more U.S. patents. See [sharkninja.com/patents](http://sharkninja.com/patents) for more information.

### BATTERY REMOVAL AND DISPOSAL

This product's remote control uses a lithium button battery. When the battery no longer has a charge, it should be removed from the remote and recycled. **DO NOT** incinerate or compost the battery.

When your lithium battery needs to be replaced, dispose of it or recycle it in accordance with local ordinances or regulations. In some areas, it is illegal to place spent lithium batteries in the trash or in a municipal solid waste stream. Return spent battery to an authorized recycling center or to retailer for recycling. Contact your local recycling center for information on where to drop off the spent battery.



### FCC WARNINGS

Note: This unit has been tested and found to comply with FCC limits for Class B digital devices. These limits are designed to provide reasonable protection against harmful interference in a residential installation. This unit generates, uses, and can radiate radio frequency energy, and if not installed and used in accordance with the instructions, may cause harmful interference to radio communications.

To see if this unit interferes with radio or television reception, try turning it off and on.

To correct any interference:

- Reorient or relocate the receiving antenna.
- Increase the distance between the unit and the receiver.
- Connect the unit to a different outlet than the receiver.
- Consult the dealer or an experienced technician for help.

Caution: Any changes or modifications to this unit not expressly approved by the party responsible for compliance could void the user's authority to operate it.