

# ***Shark***

## **MATRIX™ PLUS 2-in-1 ROBOT**

### **Robot Vacuum**

RV2600WA Series

### **OWNER'S GUIDE**

---



# IMPORTANT SAFETY INSTRUCTIONS

PLEASE READ CAREFULLY BEFORE USE • FOR HOUSEHOLD USE ONLY

If the charging cable plug does not fit fully into the outlet, reverse the plug. If it still does not fit, contact a qualified electrician. DO NOT force into outlet or try to modify to fit.

## ⚠ WARNING

To reduce the risk of fire, electric shock, injury, or property damage:

### GENERAL WARNINGS

When using an electrical appliance, basic precautions should always be followed, including the following:

1. This appliance consists of a Robot Floor Cleaner and charging base with power supply. These components contain electrical connections, electrical wiring, and moving parts that potentially present risk to the user.
2. Place the cords from other appliances out of the area to be cleaned.
3. Before each use, carefully inspect all parts for any damage. If a part is damaged, discontinue use.
4. Use only identical replacement parts found on [sharkclean.com](http://sharkclean.com)
5. This Robot Floor Cleaner contains no serviceable parts.
6. Use only as described in the Owner's Guide provided on [sharkclean.com](http://sharkclean.com). **DO NOT** use Robot Floor Cleaner for any purpose other than those described in the Owner's Guide.
7. With exception of the filters, dust bin, and pads, **DO NOT** expose any parts of the Robot Floor Cleaner to water or other liquids.
8. **DO NOT** put hands into any opening in the base or robot.

### USE WARNINGS

9. This appliance can be used by persons with reduced physical, sensory, or mental capabilities or lack of experience and knowledge if they have been given supervision or instruction concerning use of the appliance in a safe way and understand the hazards involved.
  - a) Children shall not play with the appliance.
  - b) Cleaning and user maintenance shall not be made by children without supervision.
10. To minimize the risk of the robot traveling beyond an unsafe boundary (stair/cliff edges, fireplaces, water hazards), establish these areas as no-go zones using the mapping feature in the SharkClean® mobile app. Upon setting the boundary, run the vacuum and visually confirm that the settings effectively prevent the robot from passing beyond the set boundary. Adjust settings as necessary.

11. Always turn off the Robot Floor Cleaner before inserting or removing the filter, dust bin, or side brushes.
12. **DO NOT** handle plug, charging dock, charging cable, or Robot Floor Cleaner with wet hands. Cleaning and user maintenance shall not be made by children without supervision.
13. **DO NOT** use the Robot Floor Cleaner without the dust bin, filter, brushroll, and side brush in place.
14. **DO NOT** damage the charging cord:
  - a) **DO NOT** pull or carry charging dock by the cord or use the cord as a handle.
  - b) **DO NOT** unplug by pulling on cord. Grasp the plug, not the cord.
  - c) **DO NOT** close a door on the cord, pull the cord around sharp corners, or leave the cord near heated surfaces.
15. **DO NOT** put any objects into nozzle or accessory openings. **DO NOT** use with any opening blocked; keep free of dust, lint, hair, and anything that may reduce airflow.
16. **DO NOT** use Robot Floor Cleaner if airflow is restricted. If the air paths become blocked, turn the vacuum cleaner off and remove all obstructions before turning on the unit again.
17. Keep all vacuum openings away from hair, face, fingers, uncovered feet, or loose clothing.
18. **DO NOT** use if Robot Floor Cleaner is not working as it should, or has been dropped, damaged, left outdoors, or dropped into water.
19. **DO NOT** place Robot Floor Cleaner on unstable surfaces.
20. If the Robot Floor Cleaner is not starting from the dock, it must be placed at least 1.5 feet (45 cm) away from any stairs or ledges.
21. **DO NOT** use to pick up:
  - a) Liquid spills.
  - b) Large objects.
  - c) Hard or sharp objects (glass, nails, screws, or coins).
  - d) Large quantities of dust (drywall dust, fireplace ash, or embers).
  - e) Smoking or burning objects (hot coals, cigarette butts, or matches).
  - f) Flammable or combustible materials (lighter fluid, gasoline, or kerosene).

- g) Toxic materials (high concentrations of chlorine bleach liquid, high concentrations of ammonia, or drain cleaning solution).
22. **DO NOT** use in the following areas:
    - a) Outdoor areas near fireplaces with unobstructed entrances.
    - b) Spaces that are enclosed and may contain explosive or toxic fumes or vapors (lighter fluid, gasoline, kerosene, paint, paint thinners, mothproofing substances, or flammable dust).
    - c) In an area with a space heater.
    - d) Near fireplaces with unobstructed entrances.
  23. Turn off the Robot Floor Cleaner before any adjustment, cleaning, maintenance, or troubleshooting.
  24. Allow all filters to air-dry completely before reinstalling them in the Robot Floor Cleaner to prevent liquid from being drawn into electric parts.
  25. **DO NOT** modify or attempt to repair the Robot Floor Cleaner or the battery yourself, except as indicated in the Owner's Guide. **DO NOT** use the vacuum if it has been modified or damaged.
  26. Remove all spilled or leaked liquid from the dock landing mat, base, or floor, as it could lead to risk of electrical shock.
  27. Try a little of the VACMOP® cleaning solution on a small, inconspicuous area of the floor to ensure the solution doesn't damage the floor.
  28. When refilling the reservoir, check for leaks, as pooled liquids are a slipping hazard and may cause electrical shock. If the reservoir is damaged, it must be replaced.
  29. Use caution walking on mopped floors, as they may be slippery while damp.
  30. For your Robot Floor Cleaner's cliff sensors to work properly, all runners, rugs, carpets, or small thresholds (like child gates) must be 8 inches from any stairs (or must be continuous and extend over the edge of the stairs). If a runner, rug, carpet, or small threshold that is less than 8 inches from the stairs cannot be moved, you must use a no-go zone to block off the stairs.
  31. **DO NOT** use as an attachment to power tools for dust collection.
  32. **DO NOT** use the vacuum on a wet surface. (unless it is a WD vacuum)
  33. **DO NOT** operate the vacuum in a room where an infant or child is sleeping.
  34. **DO NOT** operate the vacuum in an area where there are lit candles or fragile

- objects on the floor to be cleaned.
35. **DO NOT** operate the vacuum in a room that has lit candles on furniture that the vacuum may accidentally hit or bump into.
  36. **DO NOT** allow children to sit on the vacuum.
- ### BATTERY USE
37. The battery is the power source for the vacuum. Carefully read and follow all charging instructions.
  38. To prevent unintentional starting, ensure the vacuum is powered off before picking it up or carrying it.
  39. Use **ONLY** the Shark® charging dock XDCK2600WA and use only battery RVBAT850A. Use of batteries or battery chargers other than those indicated may create a risk of fire.
  40. Keep the battery away from all metal objects such as paper clips, coins, keys, nails, or screws. Shorting the battery terminals together increases the risk of fire or burns.
  41. Under abusive conditions, liquid may be ejected from the battery. Avoid contact with this liquid, as it may cause irritation or burns. If contact occurs, flush with water. If liquid contacts eyes, seek medical help.
  42. Robot Floor Cleaner should not be stored, charged, or used at temperatures below 50°F (10°C) or above 104°F (40°C). Ensure the battery and vacuum have reached room temperature before charging or use. Exposing the robot or battery to temperatures outside of this range may damage the battery and increase the risk of fire.
  43. **DO NOT** expose the Robot Floor Cleaner or battery to fire or temperatures above 265°F (130°C) as it may cause explosion.
  44. Non-rechargeable batteries cannot be recharged.
- ### NO-GO ZONES
45. Always use no-go zones around reflective flooring and surfaces.
  46. No-go zones should always be used near carpeted stairs.
  47. **DO NOT** use no-go zones within 10 feet of the dock.
- ### LASER WARNING
48. This product has a Class 1 laser. It is safe under reasonably foreseeable conditions (as defined in the Owner's Guide). Always turn off the power before lifting the Robot Floor Cleaner or performing any maintenance on it.
  49. **DO NOT** look directly into laser.

## SAVE THESE INSTRUCTIONS

For the latest warnings and cautions, go to [sharkclean.com/AIRobotSE](http://sharkclean.com/AIRobotSE)

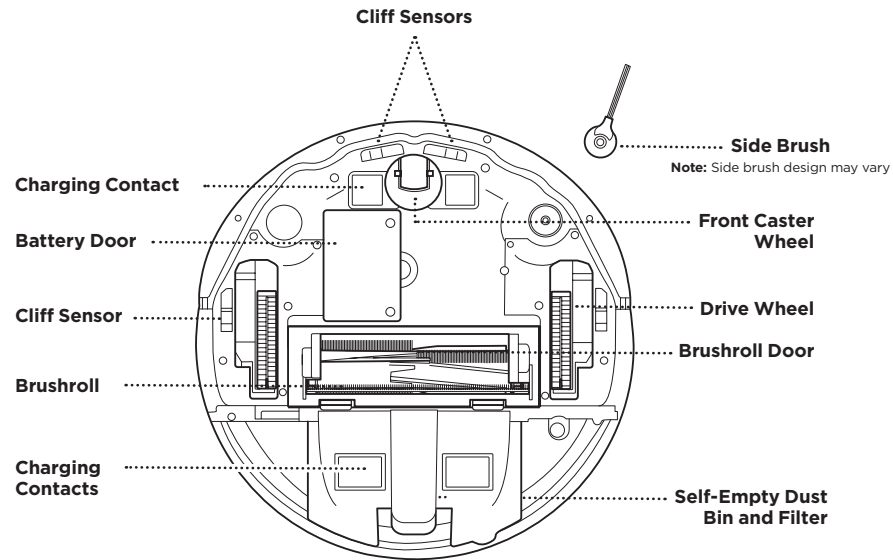
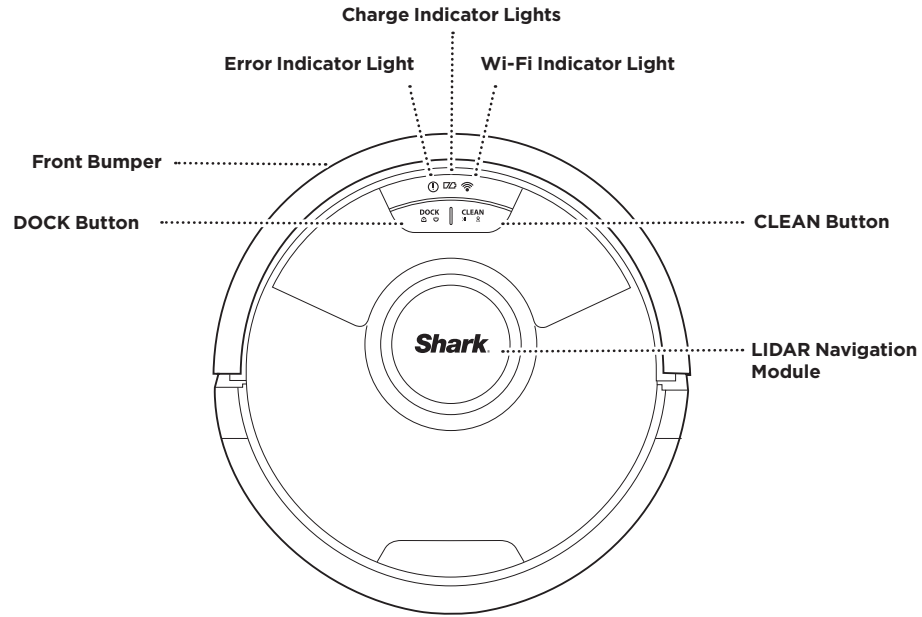

**DUST BINS**

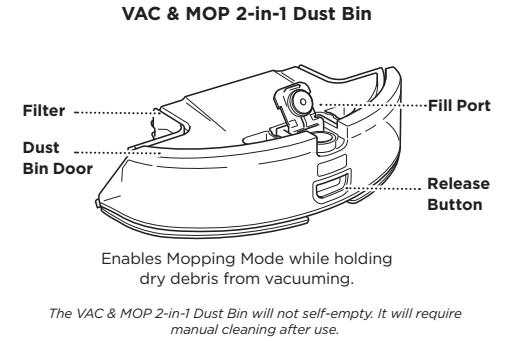
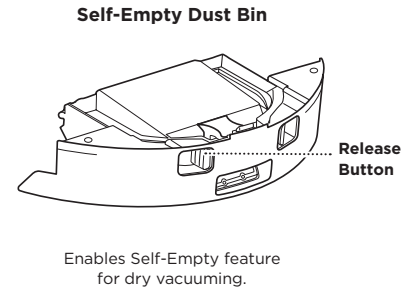

**SELF-EMPTY BASE**

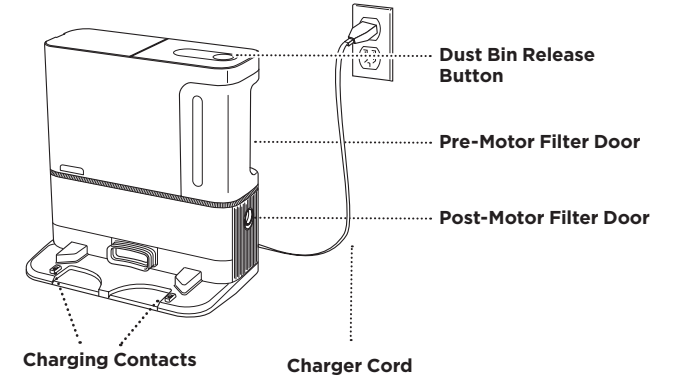

**BASE LANDING MAT**  
(This side up)

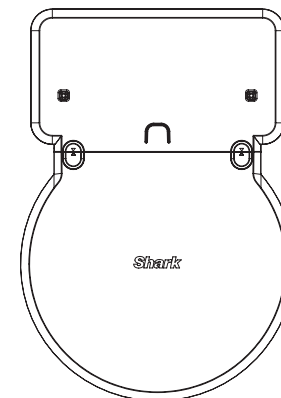

## BASE SETUP

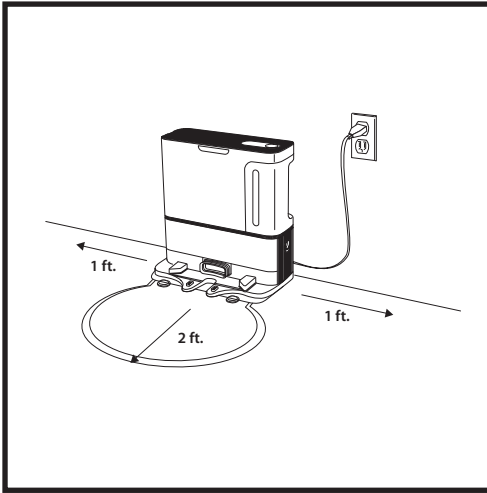

The Base Power Indicator Icon

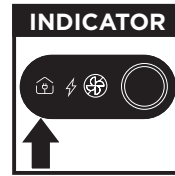

- Select a **permanent** location for the **Base**. Remove protective film from robot and base.
- Place the base with its back against a wall. Select a level surface on a bare floor in a central area with a **strong Wi-Fi signal**. Do not place base against baseboard heaters or other heating elements.
- **Remove any objects** that are closer than 1 foot from either side of the base or closer than 2 feet from the front of the base.
- Plug in the base. Make sure the power switch on the back of the base is in the (I) ON position. The Base Power Indicator icon () on the top right side of the base will **illuminate when the base has power**.

If the base is relocated after setup, the robot may not be able to find its way back, and the robot will have to completely re-map your home.

## INSTALLING THE SIDE BRUSH

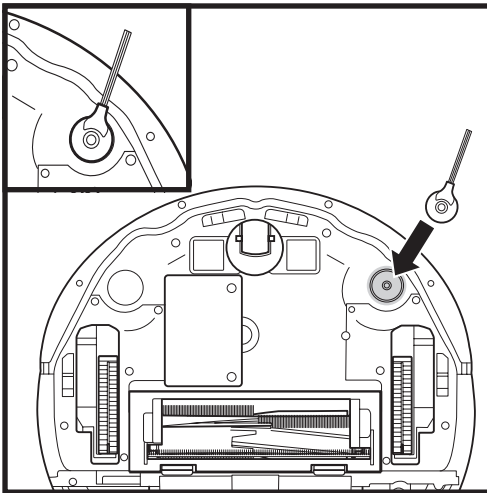

Snap the included side brush onto the square peg on the bottom of the robot. The brush will spin clockwise when correctly assembled.

**Note:** Side brush design may vary.

## ROBOT BATTERY INDICATOR LIGHTS

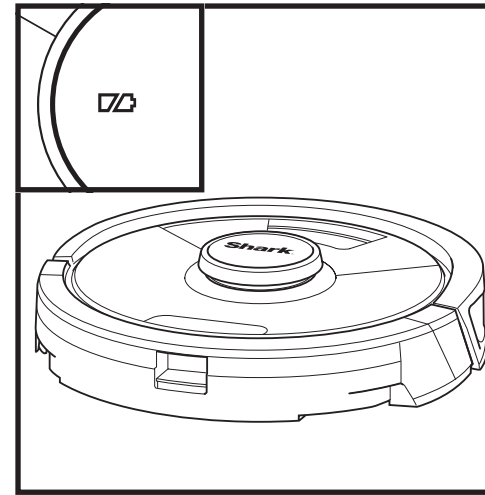

In Use



While Charging (White)



No Charge or Off



The white charge indicator lights show how much battery power is remaining.

While the robot is charging, both white LED lights will flash. When charging is complete, both will illuminate steadily. It may take up to 6 hours to fully charge your robot.

If the robot is idle and away from the charging base for 10 minutes, it will enter **Sleep Mode**. The indicator lights will turn off, but the battery and Wi-Fi lights will remain on in sleep mode. Wake up the robot by pressing any button.

**NOTE:** If the low charge light is blinking red, there is not enough battery power for the robot to return to the base. Manually place the robot on the base.

**TIP:** To preserve battery life, if the robot will not be used for a long time, turn off the power on the robot by pressing the DOCK button and holding it for 5-7 seconds. The robot should be recharged at least once every three months.

## BASE INDICATOR LIGHTS

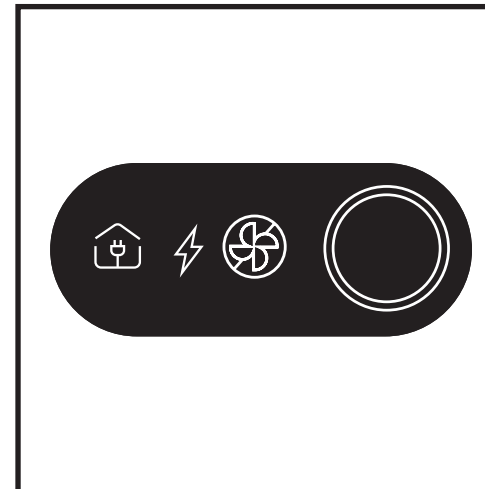

Base Power Indicator Icon



Base is plugged in and has power.

Charging Icon



Robot is properly aligned on base and charging.

No Evacuation Icon



Robot will not self-empty debris into base.

## CHARGING

**IMPORTANT:** The Shark Matrix™ Plus 2-In-1 Robot has a pre-installed rechargeable battery. Charge the battery completely before first use. It may take up to 6 hours to fully charge.

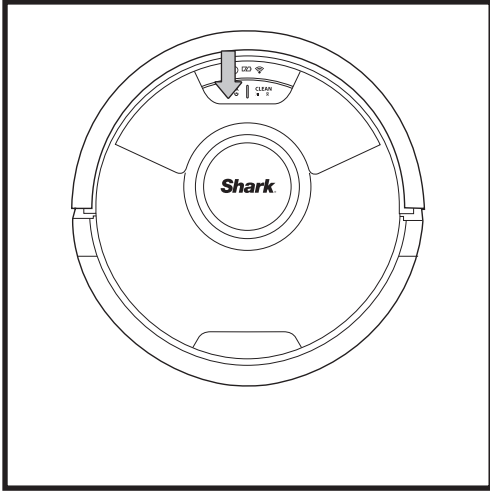

To turn ON the robot, press and hold the DOCK button for 5-7 seconds. To charge, place the robot on the base. The robot will beep when charging begins and the charging indicator on the base will illuminate.

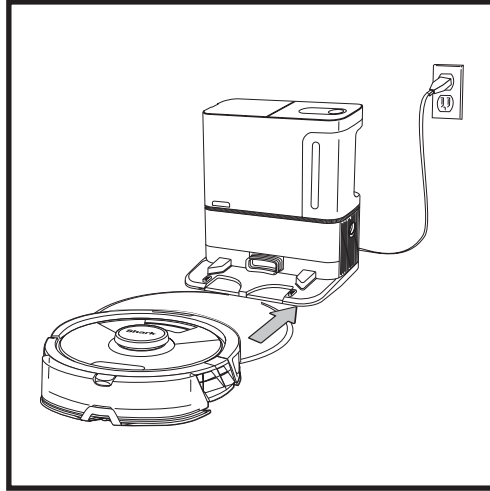

When the cleaning cycle is complete, or if the battery is running low, the robot will search for the base. If the robot doesn't return to the base, its charge may have run out, or if it is in mopping mode, the base may be blocked by carpet.

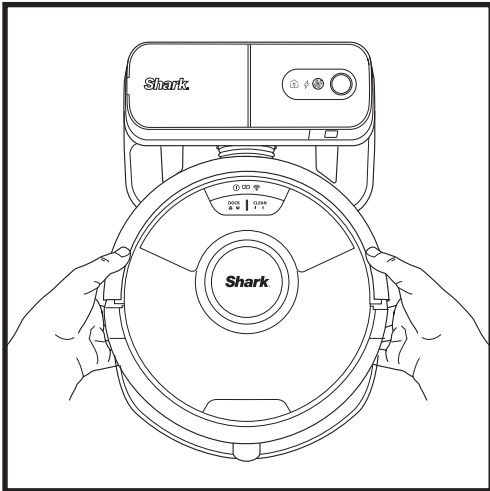

When the Vac & Mop 2-in-1 Dust Bin is installed and the robot is properly aligned on the base with the robot's **FRONT** against the base, the **Charging Symbol** on the top right side of the base will illuminate. The robot will beep when charging begins.

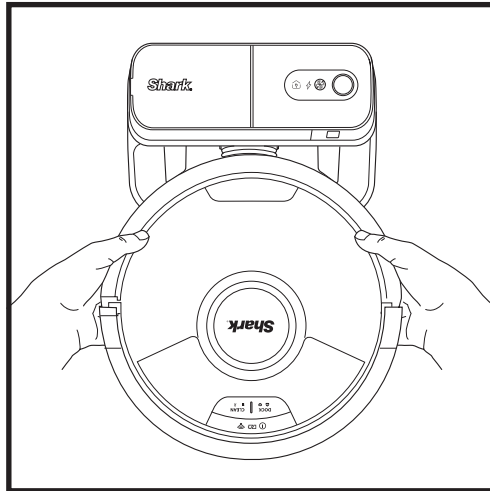

When the Self-Empty Dust Bin is installed, the robot will dock with its **BACK** to the base so that it can automatically empty itself.

**NOTE:** If the robot has no charge or it cannot return to the base, manually place it on the base. When manually placing the robot on the base, make sure the **Charging Contacts** on the bottom of the robot are touching the ones on the base. The mopping pad should not come in contact with the charging contacts. This may cause corrosion. When picking up the robot, be careful not to place fingers between the bumper and the base of the robot.

## BUTTONS AND INDICATOR LIGHTS

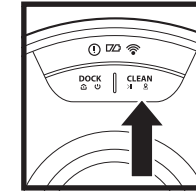
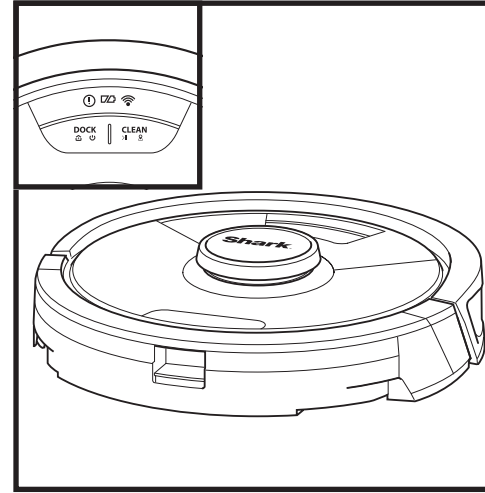

**CLEAN BUTTON**  
Press to begin a cleaning session and press again to pause the cleaning session. To activate Spot Clean to focus on a 5-foot-by-5-foot area, press and hold the CLEAN button for 5 seconds.

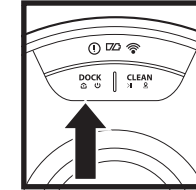

**DOCK BUTTON**  
Press to send the robot back to the base. To turn the robot power off, take it off the Self-Empty Base and press the DOCK button on the robot for 5-7 seconds.

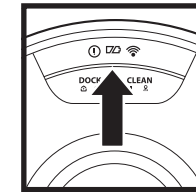

**CHARGE INDICATOR LIGHTS**  
Display the amount of charge remaining in the battery.

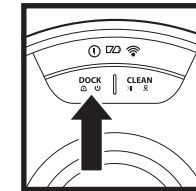

**WET MOPPING INDICATOR**  
The area above the DOCK button will illuminate blue when the fluid reservoir is properly installed. The DOCK button will illuminate yellow if the tank is empty and needs refilling.

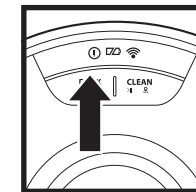

**“!” ERROR INDICATOR**  
See Troubleshooting section for full list of error codes.

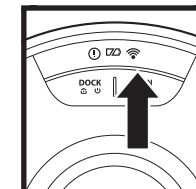

**WI-FI INDICATOR**  
White light: connected to Wi-Fi.  
Red light: disconnected.  
Flashing White: setup mode.  
No light: not set up yet.

## PREP YOUR HOME

Your robot uses an array of sensors to navigate around walls, furniture legs, and other obstacles while it cleans. To prevent the robot from entering areas you don't want it to, set up no-go zones in the app. For best results, prepare your home as indicated below, and schedule a daily cleaning to ensure all floor areas are regularly maintained.

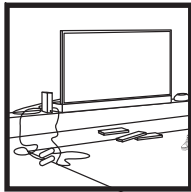

### OBSTRUCTIONS

Clear cords and small objects less than 4.5" in height, and open interior doors to ensure a complete map of your home.

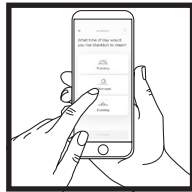

### SCHEDULING

While your robot is cleaning do not pick it up and move it, this will impact the robot's navigation. If you move the charging base to a new location, you will need to remap your home. This will impact the robot's ability to return to the dock when cleaning is complete.

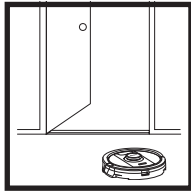

### THRESHOLDS

Your robot can climb over most thresholds to get from room to room, but if one is too high, set up a no-go zone in the app to block it off.

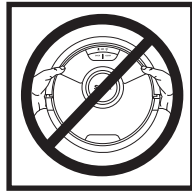

### AVOID MOVING THE ROBOT OR BASE

While your robot is cleaning, do not pick it up and move it, as this will impact the robot's navigation. If you move the charging base to a new location, you will need to re-map your home. This will impact the robot's ability to return to the dock when cleaning is complete.

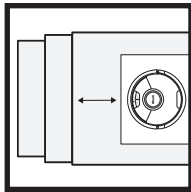

### STAIRS

For your robot's cliff sensors to work properly, all runners, rugs, carpets, or small thresholds (like child gates) must be 8 inches from any stairs (or must be continuous and extend over the edge of the stairs). If a runner, rug, carpet, or small threshold is near the stairs and cannot be moved, you must use a no-go zone to block off the stairs.

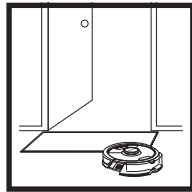

### REMOVE RUGS FROM DOORWAYS WHEN MOPPING

Before mopping, we recommend setting up Carpet Zones in the app, and moving any carpets or rugs that block access to floors that you want your robot to mop.

## MANUAL CLEANING MODE

To manually start a cleaning cycle, press the **CLEAN** button on the robot or on the mobile app. To immediately send the robot back to the base, press the **DOCK** button.

**IMPORTANT:** Before cleaning an entire room for the first time, we recommend that you first test your robot on a small section of the floor to ensure there is no scratching.

## USING THE SHARK MATRIX™ PLUS 2-IN-1 ROBOT

### AI LASER NAVIGATION™

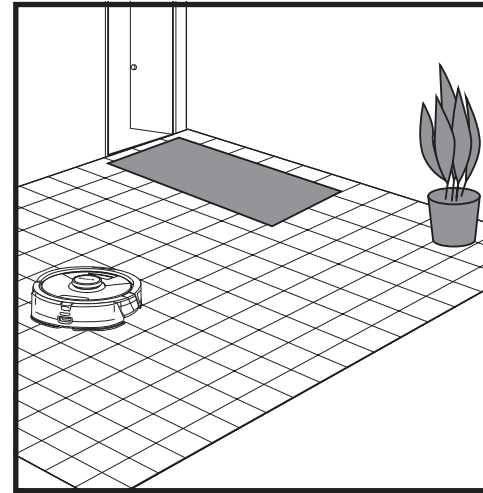

After setup is complete, follow instructions in the app to help your robot conduct an **Explore Run** to create an initial map of your home. Ensure the Self-Empty Dust Bin is inserted for the Explore Run.

The robot will travel from room to room to identify walls, furniture, and other obstacles as it cleans. This run will take less time than a full cleaning, as it doesn't cover the entire floor.

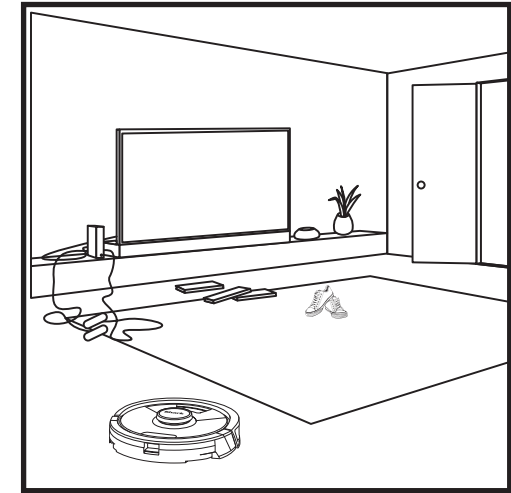

The robot's object detection technology helps it navigate around obstacles taller than 4.5" in height. Clear away small objects that may interfere with the cleaning path of your robot.

Create no-go zones in the app to block off areas you do not want the robot to enter.

### VACUUM-ONLY SETUP

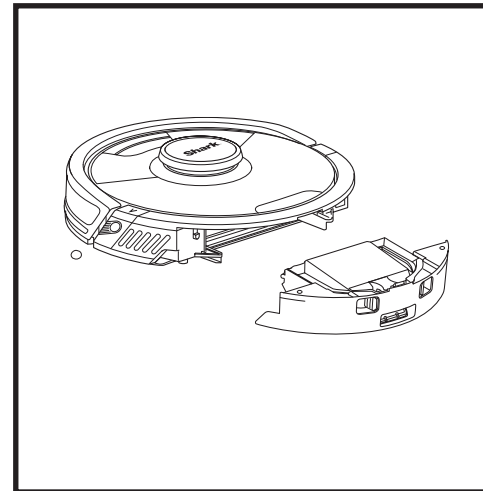

To vacuum with the Self-Empty feature, use the Self-Empty Dust Bin. Do not install the Vac & Mop 2-in-1 Dust Bin.

**NOTE:** Be sure to charge the robot completely before its first cleaning so that it can explore, map, and clean as much of your home as possible. It may take up to 6 hours to fully charge your robot.



## VAC & MOP 2-IN-1 CLEANING MODE

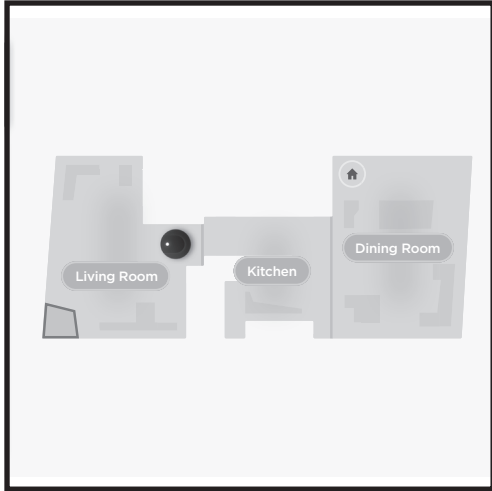

### Whole-Home Cleaning

To start a whole-home Vac & Mop run, press the CLEAN button on the robot or in the app. The robot will clean perimeter areas first, then change to a row-by-row pattern. If the fluid reservoir empties before the whole-home run is complete, the robot will pause for up to 10 minutes to allow you to refill the reservoir before it returns to the base. When the whole-home run is complete, the robot will return to its base.

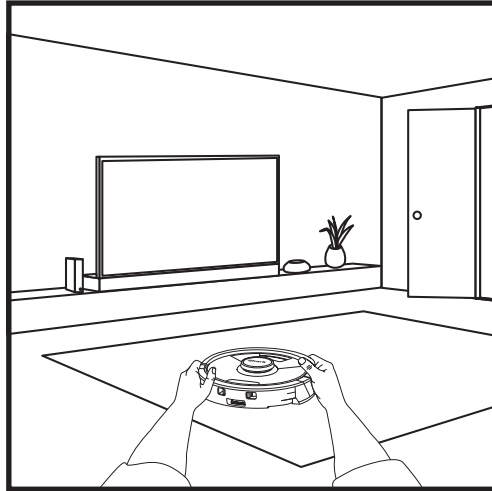

### Single-Room Matrix Clean

Once the robot has a created map, you can select a specific room to be cleaned in UltraClean mode. Place the robot in the room to be cleaned, then press the CLEAN button. This function is also available through the app.

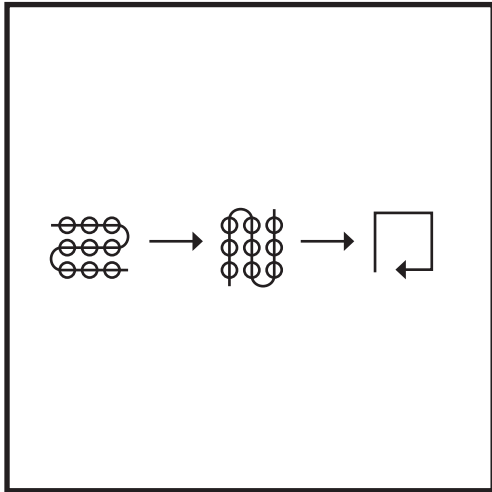

### Spot Clean

To clean a specific 5-foot-by-5-foot spot, place the robot in the area to be cleaned, then press and hold the CLEAN button for 5 to 7 seconds. The robot will rotate while vacuuming and mopping the area in a matrix pattern. Spot Clean is also available through the app.

## VACUUM-ONLY CLEANING MODES

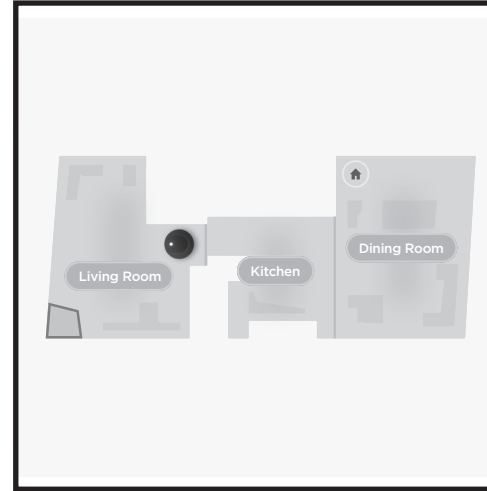

### Whole-Home Cleaning

To activate a whole-home clean when in vacuum-only mode, press the CLEAN button on the robot or in the app. The robot will clean perimeter areas first, then change to a row-by-row pattern.

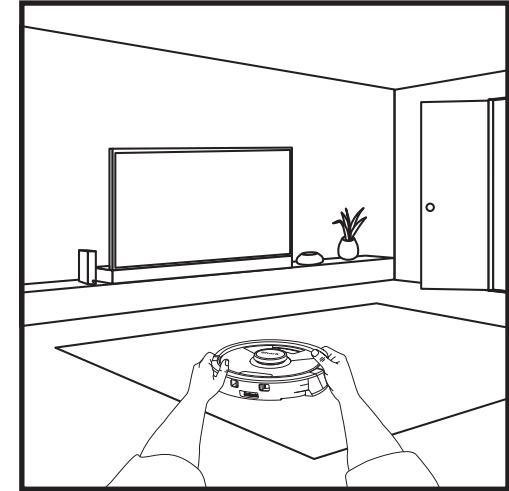

### Single-Room Matrix Clean

Once the robot has a created map, you can select a specific room for it to vacuum in UltraClean mode. Place the robot in the room to be cleaned, then press the CLEAN button. This function is also available through the app.

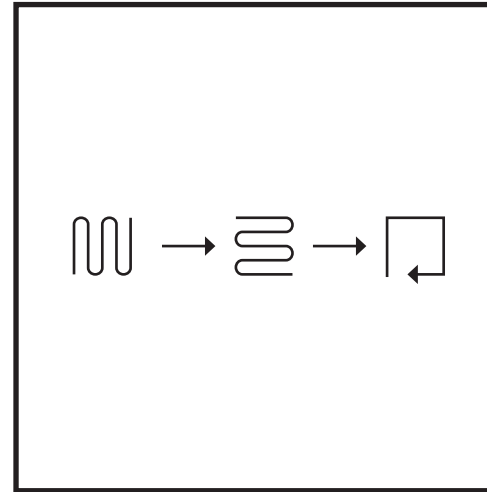

### Spot Clean

To clean a specific 5-foot-by-5-foot spot, place the robot in the area to be cleaned, then press and hold the CLEAN button for 5 to 7 seconds. The robot will clean the area in a matrix pattern. Spot Clean is also available through the app.

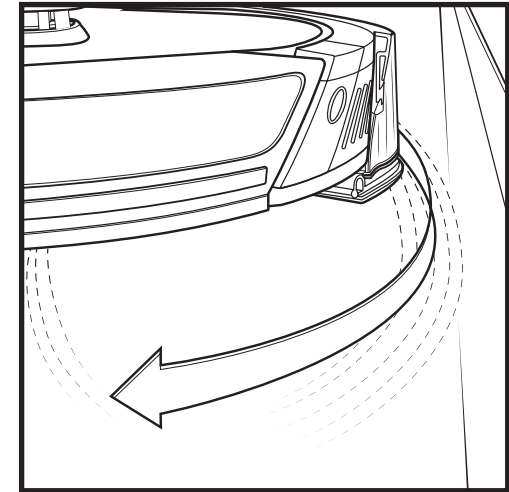

### CleanEdge

In CleanEdge mode, the fanjet blows air into the edges and corners of the room so that the robot can easily pick up debris from hard-to-clean areas. CleanEdge is automatically activated when the robot runs alongside walls at the start of its run, then turns off when the robot cleans the rest of the area.

## USING THE SHARK MATRIX™ PLUS 2-IN-1 ROBOT

### VAC & MOP 2-IN-1 SETUP

**NOTE:** Before it can mop, the robot **MUST** complete an **Explore Run** with the Self-Empty Dust Bin attached. After the Explore Run, you will have an option to set up Carpet Zones and verify those carpets in the app with a Carpet Verification Run. This ensures your robot will avoid carpets in mopping mode.

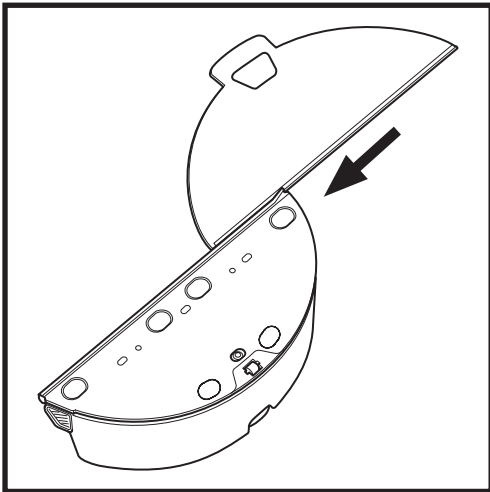

Attach the mop pad by inserting the flat edge of the pad through the slot in the Vac & Mop 2-in-1 Dust Bin. Pull the mop pad all the way through the slot until it is securely inserted.

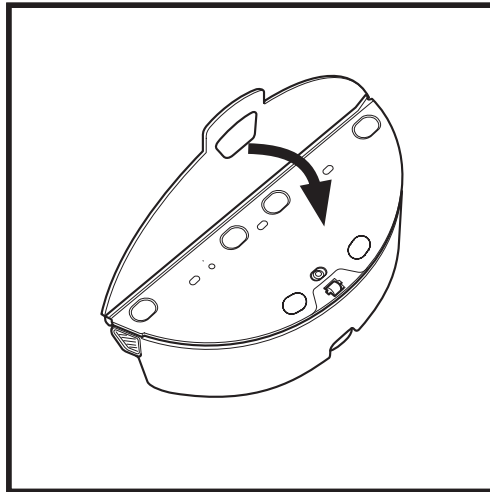

Secure the pad to the Vac & Mop 2-in-1 Dust Bin.

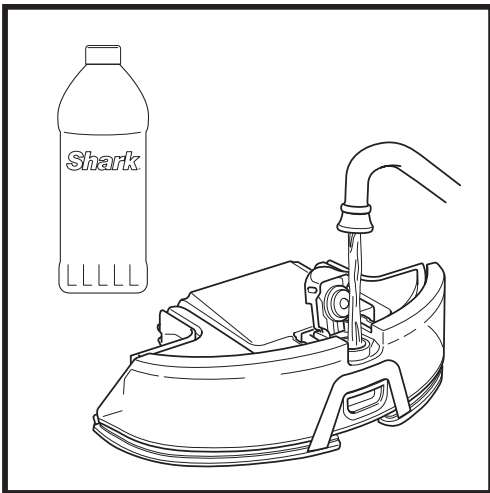

Lift open the fill cap on the top of the reservoir. Fill with water to the WATER line, then add VACMOP® cleaning solution, to the VACMOP CLEANER line. Close the cap and make sure it is properly sealed. We recommend using only Shark VACMOP cleaning solution and water. Other cleaning solutions may negatively impact your robot's performance in mopping mode.

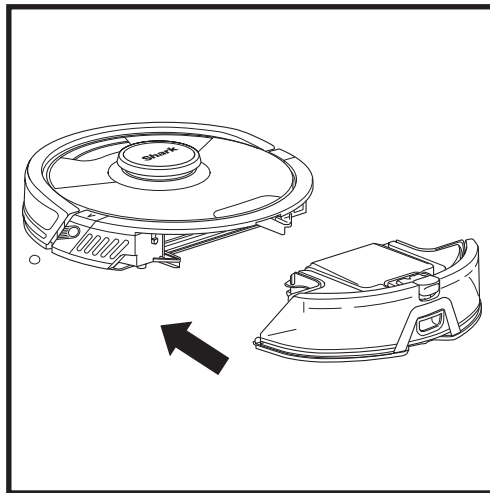

Firmly push the Vac & Mop 2-in-1 Dust Bin into the back of the robot, and ensure both latches click into place. The **CLEAN** button on the robot will illuminate blue when the Vac & Mop 2-in-1 Dust Bin is inserted properly.

## USING THE SHARK MATRIX™ PLUS 2-IN-1 ROBOT

### VAC & MOP 2-IN-1 SETUP

**NOTE:** Before the first mopping run, remove any rugs or mats from the robot's path. You can also prevent your robot from traveling over rugs and carpets by setting up Carpet Zones in the app.

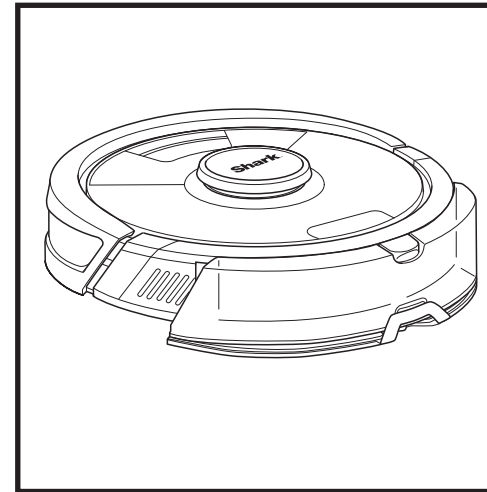

When the reservoir in the Vac & Mop 2-in-1 Dust Bin has fluid and is properly installed, with the mop pad attached, the robot is ready to vacuum and mop simultaneously. Press the **CLEAN** button on the robot or in the app to start a vacuuming and mopping run. The robot will pre-saturate the mop pad before starting its run.

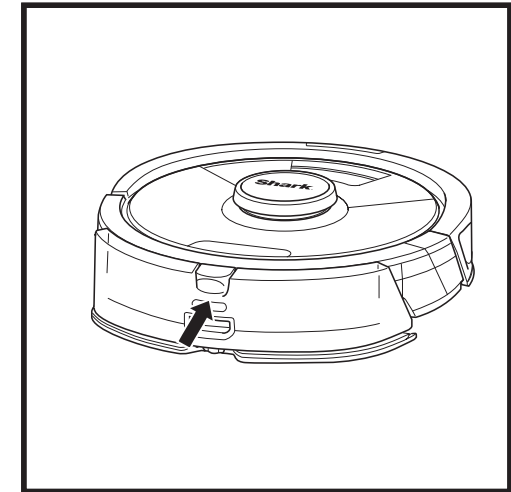

When mopping is complete, remove the Vac & Mop 2-in-1 Dust Bin by pressing the fill port button and sliding it out. Empty the reservoir after each use and manually clean out the dust bin.

**CAUTION:** Floors may be slippery after mopping.

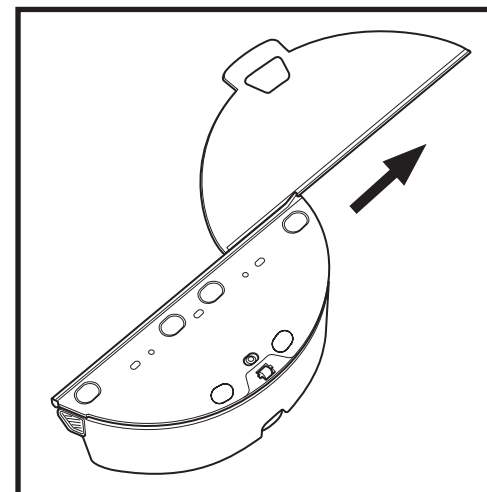

To remove the mop pad from the Vac & Mop 2-in-1 Dust Bin, detach the pad from the reservoir and slide the pad out of the slot.



## MAINTENANCE

### EMPTYING THE BASE DUST BIN

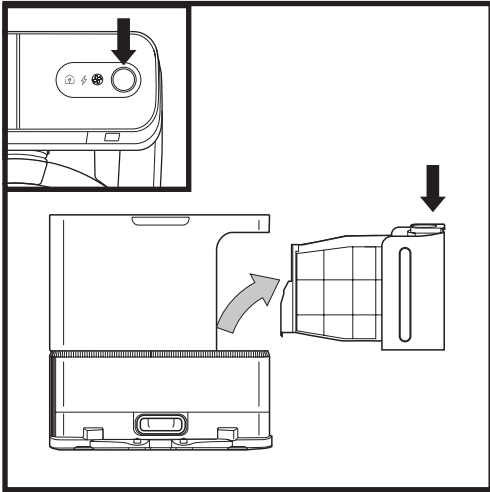

The **Base Dust Bin** holds up to 60 days' worth of dust and debris. Empty the base dust bin when the debris level approaches the max fill line.

To detach the bin, press the **Dust Bin Release** button on top right side of the base, then slide out the bin.

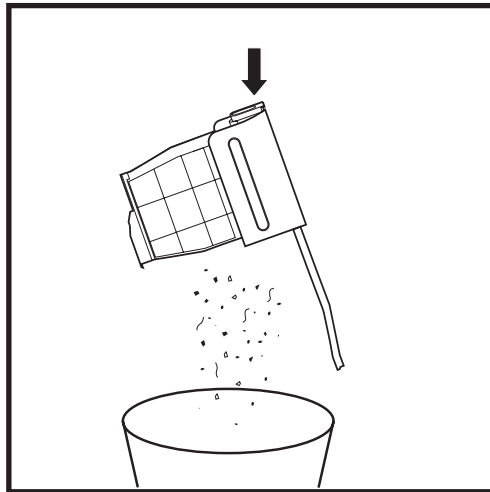

To empty the bin, hold it over the trash, then press the release button with the trash can icon on the bottom of the bin. The bin lid will open, releasing dust and debris. Lightly tap the dust bin against the inside of the trash receptacle to knock off any remaining debris. Reinstall the bin by sliding it into the slot in the base until it clicks into place.

## MAINTENANCE

To turn the robot power off, take it off the Self-Empty Base and press the DOCK button on the robot for 5-7 seconds.

**CAUTION:** Turn off power before performing any maintenance.

### MAINTAINING THE VAC & MOP 2-IN-1 DUST BIN

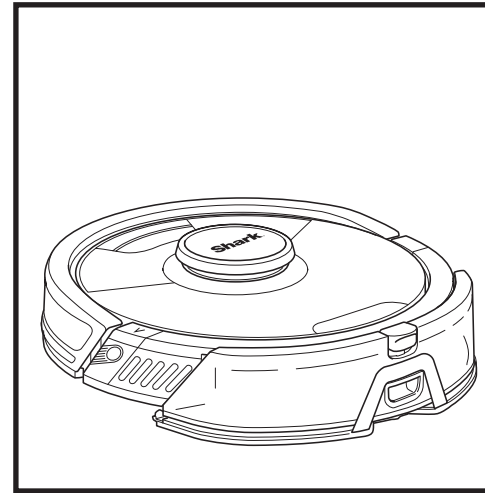

For the **Vac & Mop 2-in-1 Dust Bin**, press the release button at the top of the dust bin and slide it out.

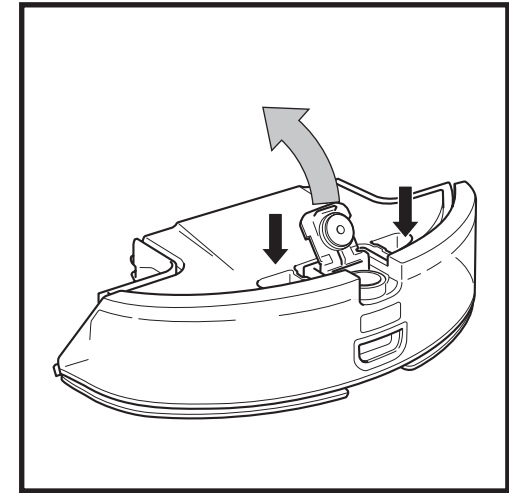

To open the dust bin lid, pinch the side latches in the finger slots and hold them while lifting the lid.

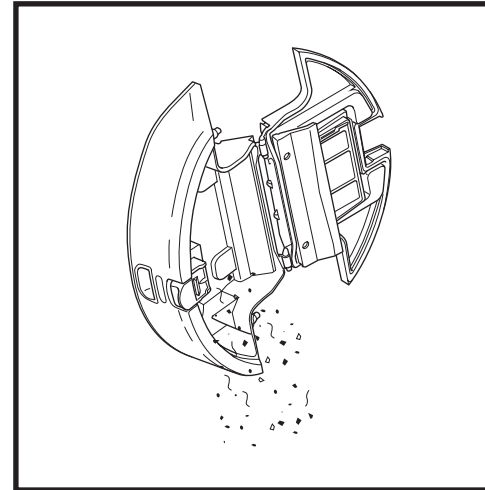

Remove the filter and use a damp cloth to wipe the dust bin clean. Allow the bin to air-dry for 24 hours before reinstalling it.

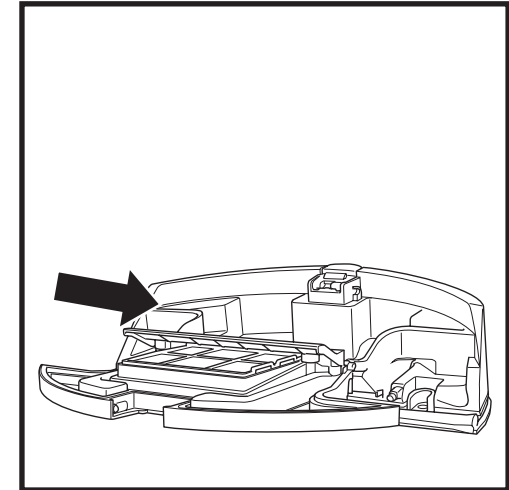

Look between the filter and the plastic shield and make sure there is no debris buildup.

**NOTE:** Make sure to insert the dust bin completely, until it clicks into place.

## MAINTENANCE

### CLEANING AND REPLACING THE BASE FILTERS

Regularly clean the filters to keep your vacuum's suction power optimal. Replace filters every 6-12 months or as needed.

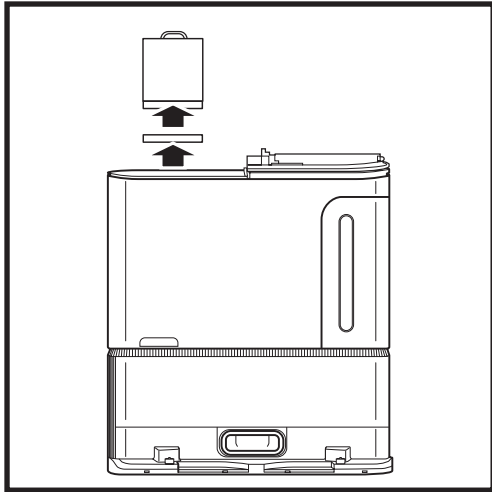

#### CLEAN PRE-MOTOR FILTERS ONCE A MONTH

To open the filter housing lid, hold the top left edge of the base and pull up on the lid. With the lid open, remove the foam filter by the top handle, then lift out the felt filter underneath. Tap the filters clean over the trash, then rinse with cold water ONLY, as soap may damage them. Allow filters to air-dry completely before reinstalling them. The filters must be installed correctly for the base to work properly. Reinsert the felt filter first, then the foam filter.

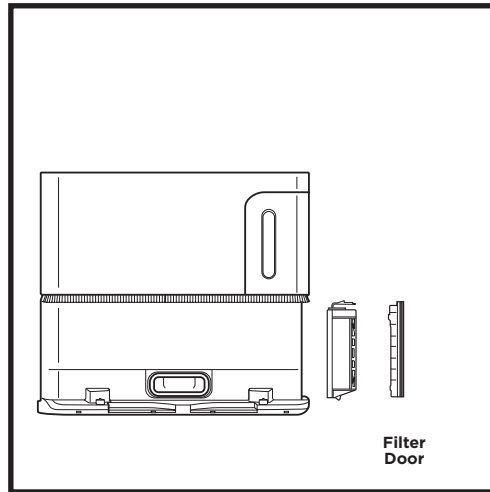

#### CLEAN POST-MOTOR FILTER EVERY YEAR

Press the button at the top of the Filter Door and slide the latch down to lift Filter Door off. Remove the **Post-Motor Filter** from the base by pulling the tab down. Tap the filters clean over the trash. Do not use water or soap to clean filters as this will cause damage. To reinstall the post-motor filter, insert it into the base and replace the filter door.

## MAINTENANCE

To turn the robot power off, take it off the Self-Empty Base and press the DOCK button on the robot for 5-7 seconds.

**CAUTION:** Turn off power before performing any maintenance.

### CLEANING THE SELF-EMPTY DUST BIN

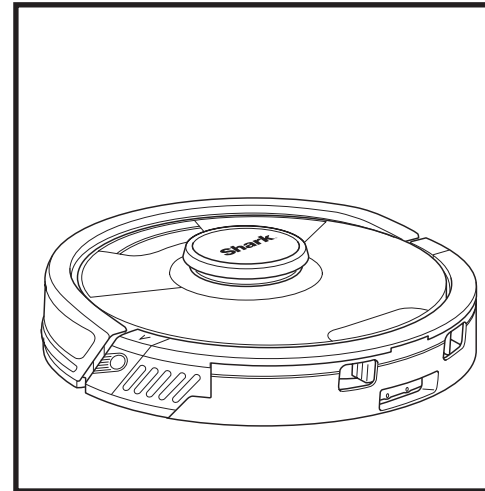

To remove the **Self-Empty Dust Bin**, pinch the release latches on the front of the dust bin and slide it out.

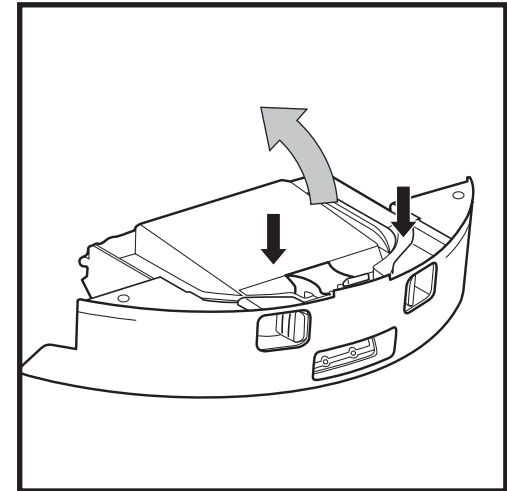

To open the dust bin lid, pinch the side latches in the finger slots and hold them while lifting the lid.

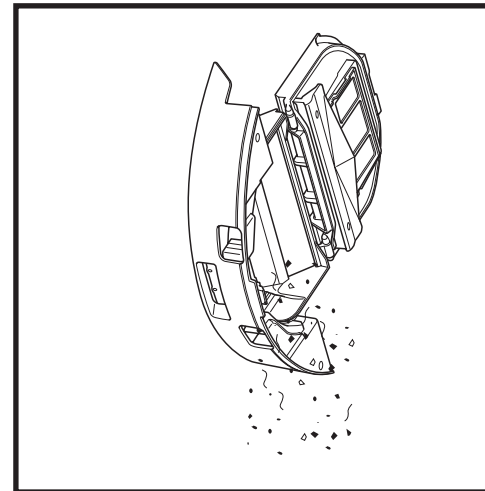

Remove the filter and use a damp cloth to wipe the dust bin clean. Allow the bin to air-dry for 24 hours before reinstalling it.

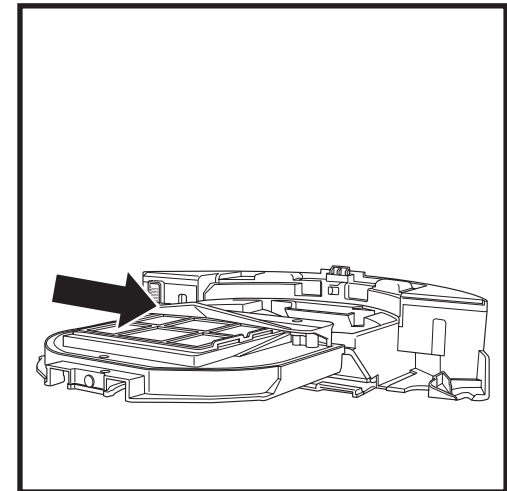

Look between the filter and the plastic shield and make sure there is no debris buildup.

**NOTE:** Make sure to insert the dust bin completely, until it clicks into place.

## MAINTENANCE

### CLEANING AND REPLACING THE ROBOT'S FILTERS

For optimal suction power, please clean and reinsert the Self-Empty Dust Bin filter after each use. See [sharkclean.com](http://sharkclean.com) for replacement parts and accessories.

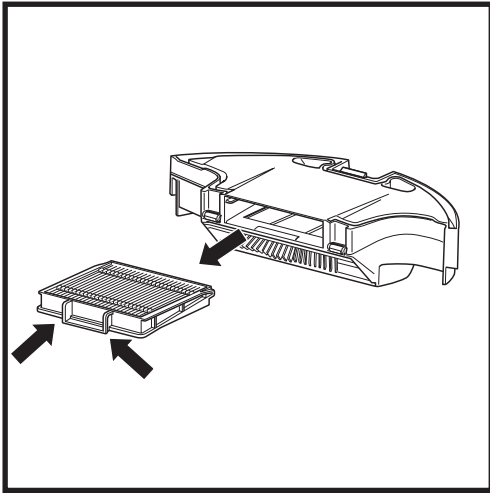

Remove and empty the Self-Empty Dust Bin. Pull filter out of the dust bin by the tabs.

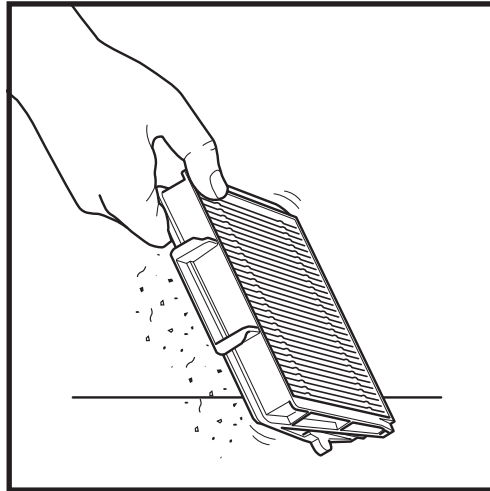

Lightly tap the filter to remove debris every time you empty the dust bin. Replace the filter every 6-12 months or as needed.

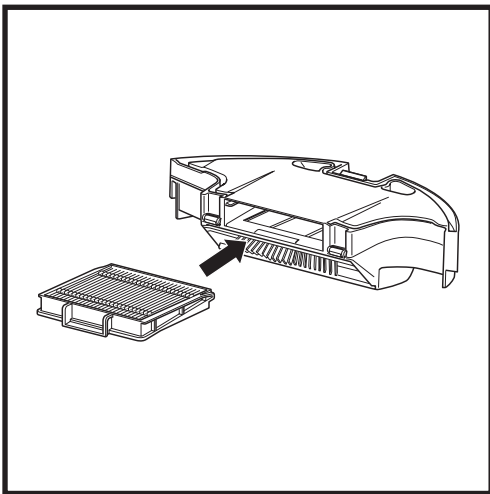

Reinsert the filter into the dust bin, then slide the dust bin back into the robot until it clicks into place.

## MAINTENANCE

### CLEANING THE VAC & MOP 2-IN-1 DUST BIN AND MOPPING PAD

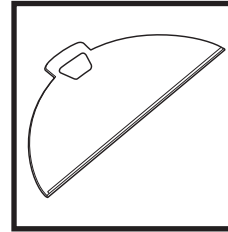

To clean pads, machine wash warm with light colors. Use mild detergents and do not use bleach or fabric softeners. Air-dry, or tumble-dry on low with no dryer sheets.

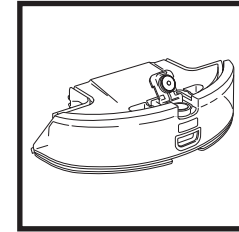

Empty the remaining liquid and the debris from the fluid reservoir after each use. Using a damp cloth, wipe the inside of the dust bin. Let the dust bin air dry for 24 hours before use. DO NOT put Vac & Mop 2-in-1 Dust Bin in the dishwasher.

**NOTE:** Before storing, make sure the Vac & Mop 2-in-1 Dust Bin and pad are completely dry. Store them in a dry place to prevent damage.

## MAINTENANCE

### CLEANING THE SELF-CLEANING BRUSHROLL

The **Self-Cleaning Brushroll** actively removes hair wrap while your robot cleans. If some debris remains wrapped around the brushroll, continue to run the robot to give the brushroll time to clean itself. If some hair wrap or debris remains after continued cleaning, carefully remove it from the brushroll.

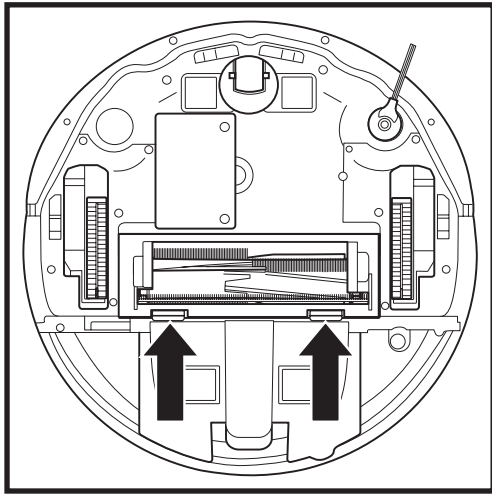

To access the brushroll, push up on the tabs on the brushroll door, then lift off the door.

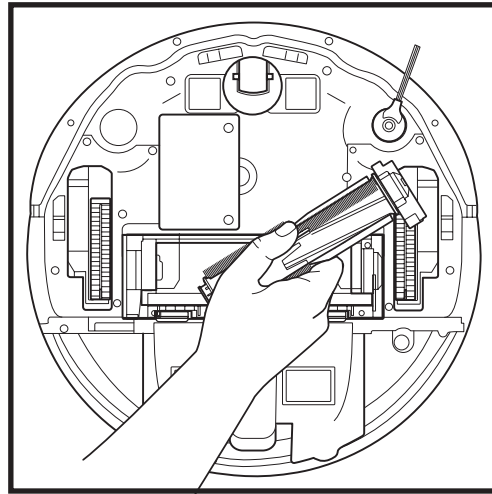

Lift out the brushroll and remove any debris. Reinstall the brushroll, inserting the flat end first. Close the brushroll door and press down until both sides click into place.

**NOTE:** Replace brushroll every 6 to 12 months, or when visibly worn. See [sharkaccessories.com](http://sharkaccessories.com) for replacement parts.

### CLEANING THE LIDAR NAVIGATION MODULE

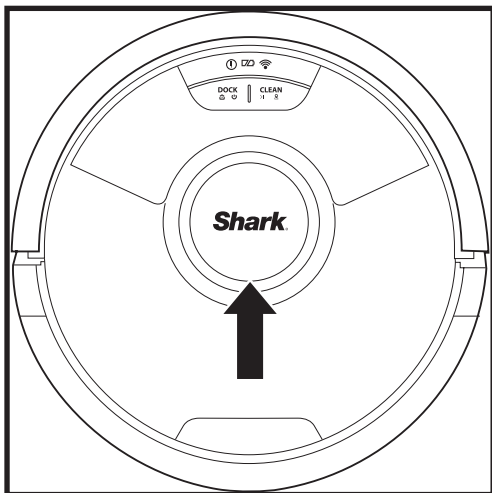

Periodically check the LIDAR navigation module on top of the robot for hair and debris. Gently wipe away any hair or debris from the module.

For a more thorough cleaning, place the robot on a level surface and turn off the power. Use a cotton swab to gently rotate the module clockwise five times.

Do not insert cotton swab inside the openings in the module.

## MAINTENANCE

### CLEANING SENSORS AND CHARGING CONTACTS

**CLEAN SENSORS AND CHARGING CONTACTS AS NEEDED.** With a dry cloth, gently dust off the sensors and contacts located on the bottom of the robot and on the base.

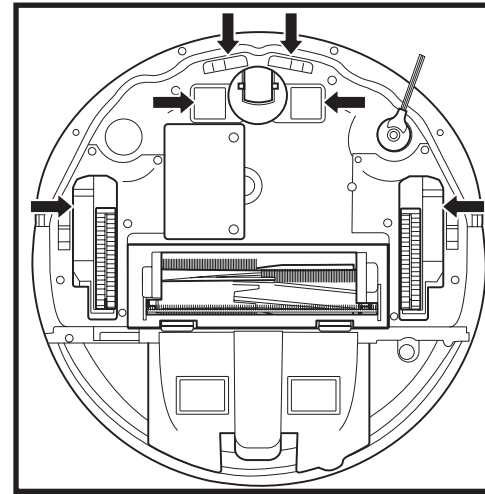

**IMPORTANT:** The robot uses cliff sensors to avoid stairs and other steep drops. Sensors may work less effectively when they are dirty. For best results, clean sensors regularly.

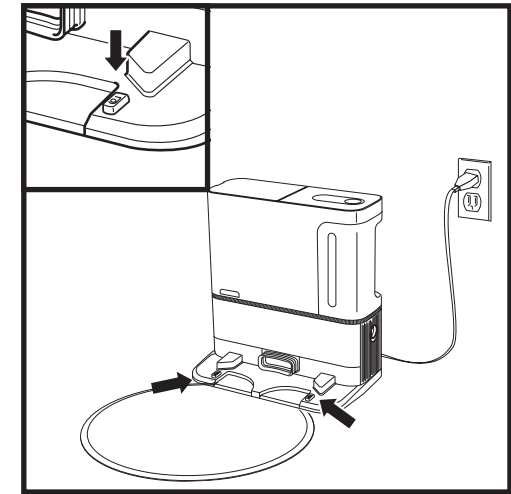

### CLEANING SIDE BRUSH

**CLEAN SIDE BRUSH AS NEEDED.**

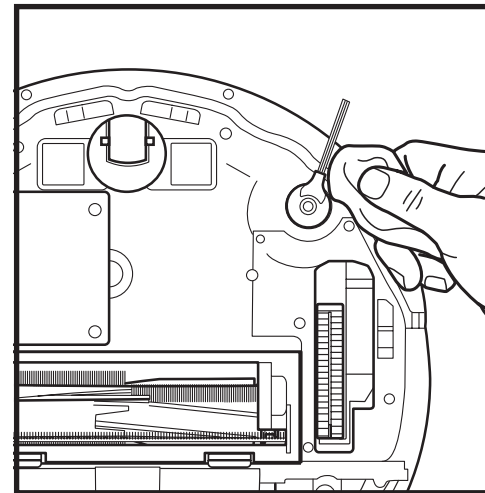

Carefully unwind and remove any string or hair wrapped around the side brush. Gently wipe brush with a dry cloth. To reinstall, snap the brush over the pegs. Spin the brush manually to make sure it is installed correctly.

**NOTE:** Remove and replace the side brush if it is bent or damaged. To remove the brush, lift it off its peg. Replace side brushes every 12 months or when visibly worn.

To get the best cleaning performance from your robot, we recommend downloading the latest version of the SharkClean® app.

USING THE SHARKCLEAN® APP AND VOICE CONTROLS

Get the most out of your robot with these app features:

- Recharge and Resume**  
 Enable this feature to handle multi-room cleaning in larger homes. The robot will return to the base, recharge, and can pick up where it left off.
- Matrix Clean:** Targeted deep cleaning for a specific room or single spot.
- No-Go Zones**  
 Use the no-go zones in the app to keep your robot out of the areas you would like it to avoid.
- Scheduling**  
 Set up whole-home cleanings for any time, any day.
- Control From Anywhere**  
 Wherever you are, you're in control of your robot.
- Cleaning Reports**  
 Each time your robot cleans, your app will generate a cleaning report. Search for **SharkClean** in the app store and download the app to your iPhone™ or Android™.
- Carpet Zone**  
 Once your robot has mapped your home, set up Carpet Zones in the app to identify areas of your carpeted floors you do not want your robot to mop.



How do I use my robot with Amazon Alexa?

Open the Amazon Alexa app, go to the menu and select Skills. Or go to the Alexa Skills store on the Amazon website. Search for "Shark Skill". Select the Shark® Skill to open the detail page, then select the Enable Skill option. Once enabled, you can ask Alexa to control your robot (i.e., "Alexa, tell Shark® to start cleaning").

How do I set up my robot with the Google Assistant on an Apple device?

1. Download, open, and sign in to the Google Assistant app. 2. Select the "Explore" icon. Search for "Shark" and select "Try it." 3. To allow Google to link to your SharkClean® account, sign in to your SharkClean account. This is the same account you used when setting up your Shark® robot in the SharkClean app. Select "Authorize" to link your SharkClean account to the Google Assistant. To send your robot in to action, use the voice command, "Google, tell Shark® to start cleaning."

How do I set up my robot with the Google Assistant on Android?

1. Download open, and sign in to the Google Assistant app. 2. Select the "Explore" icon. Search for "Shark" and select "Link." 3. Sign in to your SharkClean account. This is the same account you used when setting up your Shark® robot in the SharkClean app. To send your robot in to action, use the voice command, "Google, tell Shark® to start cleaning."

HERE ARE SOME THINGS YOU CAN SAY TO GOOGLE ASSISTANT OR AMAZON ALEXA.

**Google Assistant:**  
 Hey Google, start vacuuming.  
 Hey Google, tell (robot name) to vacuum.  
 Hey Google, pause vacuuming.  
 Hey Google, tell (robot name) to go home.  
 Hey Google, ask Shark® to UltraClean my (room name).

**Amazon Alexa:**  
 Alexa, ask Shark® to start vacuuming/cleaning the (room name).  
 Alexa, start/stop the vacuum.  
 Alexa, send the vacuum to base.  
 Alexa, ask Shark® to UltraClean my (room name).

What should I do if my Wi-Fi randomly disconnects?

It is normal for your robot to temporarily lose connectivity when it goes under furniture or moves far from your router. Your Shark® robot will automatically reconnect to Wi-Fi. If the robot does not reconnect, power it off, wait 10 seconds, power the robot back on, and place it back on the base. Take the robot off the base and press and hold the DOCK button on the robot for 5-7 seconds to turn off power. Place the robot back on the base to turn power back on. Turn off your phone. Wait 30 seconds, then turn your phone back on. Open Wi-Fi settings on your phone, find the Shark® network, and select Forget Network. Reopen SharkClean app and retry the connection process.

What should I do if I verified a wireless network password that is incorrect?

Close the app, then reopen it. Make sure that you entered the correct Wi-Fi network password this time. In your phone's network settings, choose your home 2.4 GHz network, and select Forget. Reconnect to your home network. Make sure to use the correct password. If you were able to connect to your home network, proceed to the app setup process. We recommend that you use the eye icon when entering your password to make sure it is correct. If you cannot locate your Wi-Fi password, please contact your Internet service provider.

What should I do if my SharkNinja user name and password is invalid?

We recommend you select the eye icon next to the password entry to verify you are entering your password correctly. Select the 'Forgot Password' option on the sign-in page. The automated system will email you a link to reset your password. If you do not see an email, search your inbox and spam folder for emails from mysharkninja@sharkninja.com. You can use the "Resend code" option to send the email again.

What should I do if there is an issue resetting password (did not receive the email or token was invalid)?

If you do not see an email, search your inbox and spam folder for emails from mysharkninja@sharkninja.com. You can use the "Resend code" option to send the email again.

WI-FI TROUBLESHOOTING

- To use the app, your phone must be connected to a **2.4 GHz** network. The app will only work on a 2.4 GHz network.
- Do not use a VPN or a proxy server.

CAN'T CONNECT?

**Reboot your robot**

- If your base has a power switch, make sure it is in the ON position.
- Take robot off base and press and hold the DOCK button on the robot for 5-7 seconds to turn off power. Place the robot back on the base to power back on.

**Restart your phone**

Turn off phone, wait a few minutes, then turn it back on and connect to Wi-Fi.

**Reboot your router**

- Unplug the router power cable for 30 seconds, then plug it back in. Allow several minutes for your router to reboot completely.

ERROR CODE	PROBLEM
! (RED) + Wi-Fi indicator (RED Flashing)	Wrong password for Wi-Fi
! (Flashing red) + Wi-Fi (RED)	SSID cannot be found, try connecting again
! + Wi-Fi (Flashing RED at the same time)	Cannot connect to Wi-Fi

## REPLACEMENT PARTS

**NOTE:** To order replacement parts and filters, visit [sharkaccessories.com](http://sharkaccessories.com).

### REPLACEMENT PARTS: ROBOT

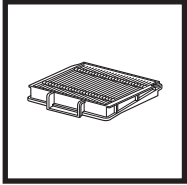

Robot Filter

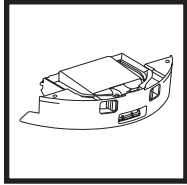

Self-Empty  
Dust Bin

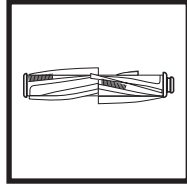

Brushroll

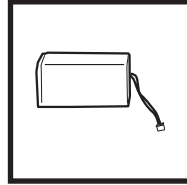

Battery

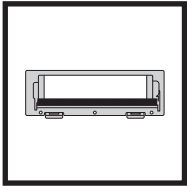

Brushroll Door

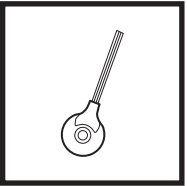

Side Brush

### REPLACEMENT PARTS: MOPPING

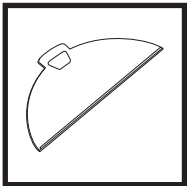

Mop Pad

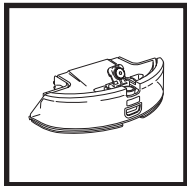

Vac & Mop 2-in-1  
Dust Bin



Shark® VACMOP®  
Multi-Surface Cleaner  
Refill 2L Bottle



Shark® VACMOP®  
Hardwood Cleaner  
Refill 2L Bottle

### REPLACEMENT PARTS: BASE

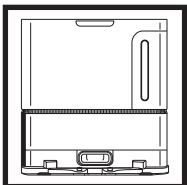

Charging Base

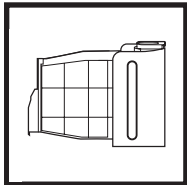

Base Dust Bin

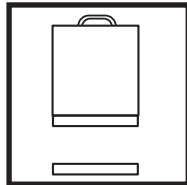

Base Pre-Motor  
Foam & Felt Filter  
Kit

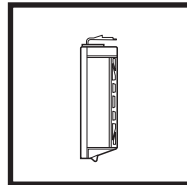

Base Post-Motor  
Filter

## ERROR CODES

If any error lights are illuminated or flashing on your Shark Matrix™ Plus 2-In-1 Robot, see the error code chart below:

ERROR CODE	SOLUTION
CLEAN (RED) flashing + ! (RED) flashing	Suction motor failure. Remove and empty the dust bin, clean the filters, and remove blockages to ensure nothing is reducing suction.
CLEAN (RED) flashing	Robot may be stuck on an obstacle. Move robot to a new location on a level surface.
DOCK (RED) flashing	Front bumper may be jammed. Clean the bumper and make sure it moves in and out freely.
CLEAN (RED) + DOCK (RED) flashing	Robot dust bin has been removed and needs to be reinserted.
DOCK (RED) + ! (RED) flashing	Side brush is stuck. Remove any debris from around the side brush.
CLEAN (RED) + DOCK (RED) + ! (RED) flashing	A drive wheel is stuck. Clean the wheels and remove any debris wrapped around the axles.
CLEAN (WHITE) + DOCK (RED) + ! (RED) flashing	Wheel motor encoder failure. Please turn the power off and back on.
CLEAN (WHITE) + ! (RED) flashing	Blockage in brushroll. Remove any debris from around the brushroll.
CLEAN (RED) + DOCK (WHITE) + ! (RED) flashing	Robot has encountered an error while booting. Please turn the power off and back on.
CLEAN (WHITE) + DOCK (RED) flashing	Robot cannot locate base. Please pick up your robot and place it on the base.
BATTERY ICON (RED) flashing	Battery is critically low and needs recharging. If your robot is unable to base, place the robot manually on the base.
CLEAN (RED) flashing + DOCK (WHITE) flashing alternating	Robot is stuck. Please move to a level surface.
CLEAN (YELLOW)	Fluid reservoir of the Vac & Mop 2-in-1 Dust Bin is empty. Refill before cleaning.



## END-USER LICENSE AGREEMENT FOR SHARKNINJA SOFTWARE

**IMPORTANT: PLEASE READ THE TERMS AND CONDITIONS OF THIS LICENSE AGREEMENT CAREFULLY BEFORE CONTINUING WITH THIS PROGRAM INSTALL OR USE OF THIS PRODUCT:** SharkNinja Operating LLC's ("SharkNinja") End-User License Agreement ("EULA") is a legal agreement between You (either a single entity or an individual) and SharkNinja for SharkNinja's Software Applications, including those installed by You onto your SharkNinja products or already installed on your device, including all firmware (referred hereafter as "SN APPS"). By installing, copying, checking a box, clicking a button confirming your agreement to these terms, or otherwise continuing to use the SN APPS, You agree to be bound by the terms of this EULA. This license agreement represents the entire agreement concerning SN APPS between You and SharkNinja, and it supersedes any prior proposal, representation, or understanding between the parties. If You do not agree to the terms of this EULA, do not install or use the SN APPS or this product. The SN APPS are protected by copyright laws and international copyright treaties, as well as other intellectual property laws and treaties.

### 1. GRANT OF LICENSE. The SN APPS are licensed as follows:

- 1.1 Installation and Use. SharkNinja grants You the right to download, install, and use SN APPS on the specified platform for which the SN APP was designed and in connection with SharkNinja products with which the SN APPS are designed to operate ("SN Devices").
- 1.2 Backup Copies. You may also make a copy of SN APPS downloaded and installed by You for backup and archival purposes.
2. DESCRIPTION OF OTHER RIGHTS AND LIMITATIONS.
  - 2.1 Maintenance of Copyright Notices. You must not remove or alter any copyright notices on any and all copies of the SN APPS.
  - 2.2 Distribution. You may not distribute copies of the SN APPS to third parties.
  - 2.3 Prohibition on Reverse Engineering, Decompilation, and Disassembly. You may not reverse engineer, decompile, or disassemble SN APPS, except and only to the extent that such activity is expressly permitted by applicable law notwithstanding this limitation.
  - 2.4 Rental. You may not rent, lease, or lend SN APPS without written permission from SharkNinja.
  - 2.5 NOT FOR RESALE SOFTWARE. Applications identified as "Not for Resale" or "NFR," may not be resold, transferred, or used for any purpose other than demonstration, test, or evaluation.
  - 2.6 Support Services. SharkNinja may provide You with support services related to SN APPS ("Support Services"). Any supplemental software code provided to You as part of the Support Services shall be considered part of SN APPS and subject to the terms and conditions of this EULA.
  - 2.7 Compliance with Applicable Laws. You must comply with all applicable laws regarding use of SN APPS.

**3. UPDATES.** SharkNinja may provide You with upgrades or updates to SN APPS. This EULA will govern any upgrades provided by SharkNinja that replace and/or supplement SN APPS, unless such upgrade is accompanied by a separate EULA, in which case the terms of that EULA will govern. If You decide not to download and use an upgrade or update provided by SharkNinja, You understand that You could put SN Apps at risk to serious security threats or cause SN Apps to become unusable or unstable.

**4. DATA AND PRIVACY.** SharkNinja is committed to ensuring your privacy by adhering to high standards of fairness and integrity. We are committed to keeping our customers informed about how we use the information we gather from You through the use of each of our websites or SN APPS. Our privacy practices are described in SharkNinja's Privacy Policy, as well as in separate notices given when an app, product, or service is purchased or downloaded. By using SN APPS or providing us with your personal information, You are accepting and consenting to the practices, terms, and conditions described in SharkNinja's Privacy Policy. At all times your information will be treated in accordance with the SharkNinja Privacy Policy, which is incorporated by reference into this EULA and can be viewed at the following URL: <http://www.sharkninja.com/privacypolicy>.

### 5. THIRD-PARTY APPLICATION LIBRARIES AND EMBEDDED SOFTWARE.

- 5.1 You acknowledge that Ayla Networks, Inc. ("Ayla") has provided certain application libraries that have been embedded into SN APPS ("Ayla Application Libraries") and enables SN Devices to connect to the Ayla Cloud Service ("Ayla Embedded Software").
- 5.2 You will not use the Ayla Application Libraries except as an incorporated portion of SN APPS, unmodified from the form provided to You.
- 5.3 You will not use the Ayla Embedded Software except as an incorporated portion of SN Devices, unmodified from the form provided to You.
- 5.4 You will not modify, adapt, translate, or create derivative works based on, or decompile, disassemble, reverse engineer, or otherwise attempt to derive the source code or underlying algorithms of, the Ayla Application Libraries or the Ayla Embedded Software.
- 5.5 SharkNinja retains all ownership of SN APPS (and the Ayla Application Libraries contained therein) and any software installed on SN Devices (including the Ayla Embedded Software) and only a license thereto is granted to You for use in connection with the SN APPS and SN Devices.

## END-USER LICENSE AGREEMENT FOR SHARKNINJA SOFTWARE

5.6 You will not use the Ayla Application Libraries or Ayla Embedded Software to attempt to gain unauthorized access to or use of the systems/services of SharkNinja's other licensors; nor will You transmit viruses, worms, Trojan horses, time bombs, spyware, malware, cancelbots, passive collection mechanisms, robots, data mining software, or any other malicious or invasive code or program into the systems/services of SharkNinja's other licensors.

5.7 You will not use the Ayla Application Libraries or Ayla Embedded Software to interfere with, breach, or circumvent any security feature, authentication feature, or any other feature that restricts or enforces limitations on the use of, or access to, the systems/services of SharkNinja's other licensors.

5.8 You will not probe, attack, scan, or test the vulnerability of the systems/services of SharkNinja's other licensors.

5.9 SharkNinja's other licensors of the SN APPS, Ayla Application Libraries, and the Ayla Embedded Software are the express third-party beneficiaries of this EULA, and the provisions of this Section of this EULA are made expressly for the benefit of such licensors, and are enforceable by such licensors.

**6. TERMINATION.** Without prejudice to any other rights, SharkNinja may terminate this EULA if You fail to comply with the terms and conditions of this EULA. In such event, You must destroy all copies of SN APPS in your possession.

**7. COPYRIGHT.** All title, including but not limited to copyrights, in and to SN APPS and any copies thereof are owned by SharkNinja or its suppliers. All title and intellectual property rights in and to the content which may be accessed through use of SN APPS are the property of the respective content owner and may be protected by applicable copyright or other intellectual property laws and treaties. This EULA grants You no rights to use such content. All rights not expressly granted are reserved by SharkNinja.

**8. OPEN SOURCE SOFTWARE.** You hereby acknowledge that SN APPS may contain software that is subject to "open source" or "free software" licenses ("Open Source Software"). The license granted by this EULA does not apply to Open Source Software contained in the SN APPS. Rather, the terms and conditions in the applicable Open Source Software license shall apply to the Open Source Software. Nothing in this EULA limits your rights under, or grants You rights that supersede, any Open Source Software license. You acknowledge that the Open Source Software license is solely between You and the applicable licensor of the Open Source Software. To the extent the terms of the licenses applicable to the Open Source Software require SharkNinja to provide the Open Source Software, in either source or executable form, or to provide copies of applicable license terms or other required information, You may obtain a copy of the software by contacting SharkNinja at the below physical address. Additional information about the Open Source Software, and its terms of use, may be found at [www.sharkclean.com/opensource](http://www.sharkclean.com/opensource).

**9. NO WARRANTIES.** SharkNinja expressly disclaims any warranty for SN APPS, Ayla Application Libraries, or Ayla Embedded Software. SN APPS, Ayla Application Libraries, and Ayla Embedded Software are provided 'As Is' without any express or implied warranty of any kind, including but not limited to any warranties of merchantability, noninfringement, fitness of a particular purpose, or title. SharkNinja does not warrant or assume responsibility for the accuracy or completeness of any information, text, graphics, links, or other items contained within the SN APPS. SharkNinja makes no warranties respecting any harm that may be caused by the transmission of a computer virus, worm, logic bomb, or other such computer program. SharkNinja further expressly disclaims any warranty or representation to any third party.

**10. LIMITATION OF LIABILITY.** In no event shall SharkNinja or its suppliers be liable for any special, incidental, punitive, indirect, or consequential damages whatsoever (including, but not limited to, damages for loss of profits or confidential or other information, for business interruption, for personal injury, for loss of privacy, for failure to meet any duty including of good faith or of reasonable care, for negligence, and for any other pecuniary or other loss whatsoever) arising out of or in any way related to the use of or inability to use SN Devices or SN APPS, the provision of or failure to provide support or other services, information, software, and related content through the product or otherwise arising out of the use of SN APPS, or otherwise under or in connection with any provision of this EULA, even in the event of the fault, tort (including negligence), strict liability, breach of contract, or breach of warranty of SharkNinja or any supplier, and even if SharkNinja or any supplier has been advised of the possibility of such damages. SharkNinja shall have no liability with respect to the content of the SN APPS or any part thereof, including but not limited to errors or omissions contained therein, libel, infringements of rights of publicity, privacy, trademark rights, business interruption, personal injury, loss of privacy, moral rights, or the disclosure of confidential information.

**11. APPLICABLE LAW.** The laws of the Commonwealth of Massachusetts will govern this EULA and You hereby consent to exclusive jurisdiction and venue in the state and federal courts sitting in the Commonwealth of Massachusetts.

**12. ASSIGNMENT.** SharkNinja may assign this EULA without notice to Licensor.

**13. ENTIRE AGREEMENT.** This EULA (including any addendum or amendment to this EULA which is included with the SN Devices) is the entire agreement between You and SharkNinja relating to the SN APPS and supersedes all prior or contemporaneous oral or written communications, proposals and representations with respect to the SN APPS or any other subject matter covered by this EULA. To the extent the terms of any SharkNinja policies or programs for support services conflict with the terms of this EULA, the terms of this EULA shall control.

If You have questions regarding this EULA, please contact SharkNinja at 89 A Street, Suite 100, Needham, MA 02494.

## ONE (1) YEAR LIMITED WARRANTY

The One (1) Year Limited Warranty applies to purchases made from authorized retailers of **SharkNinja Operating LLC**. Warranty coverage applies to the original owner and to the original product only and is not transferable.

SharkNinja warrants that the unit shall be free from defects in material and workmanship for a period of one (1) year from the date of purchase when it is used under normal household conditions and maintained according to the requirements outlined in the Owner's Guide, subject to the following conditions and exclusions:

### What is covered by this warranty?

1. The original unit and/or non-wearable components deemed defective, in SharkNinja's sole discretion, will be repaired or replaced up to one (1) year from the original purchase date.
2. In the event a replacement unit is issued, the warranty coverage ends six (6) months following the receipt date of the replacement unit or the remainder of the existing warranty, whichever is later. SharkNinja reserves the right to replace the unit with one of equal or greater value.

### What is not covered by this warranty?

1. Normal wear and tear of wearable parts (such as foam filters, filters, etc.), which require regular maintenance and/or replacement to ensure the proper functioning of your unit, are not covered by this warranty. Replacement parts are available for purchase at [sharkaccessories.com](http://sharkaccessories.com).
2. Any unit that has been tampered with or used for commercial purposes.
3. Damage caused by misuse (e.g., vacuuming up water or other liquids), abuse, negligent handling, failure to perform required maintenance (e.g., not cleaning the filters, not removing debris from the brushroll), or damage due to mishandling in transit.
4. Consequential and incidental damages.
5. Defects caused by repair persons not authorized by SharkNinja. These defects include damages caused in the process of shipping, altering, or repairing the SharkNinja product (or any of its parts) when the repair is performed by a repair person not authorized by SharkNinja.
6. Products purchased, used, or operated outside North America.

### How to get service

If your appliance fails to operate properly while in use under normal household conditions within the warranty period, visit [sharkclean.com/support](http://sharkclean.com/support) for product care and maintenance self-help. Our Customer Service Specialists are also available at **1-888-228-5531** to assist with product support and warranty service options, including the possibility of upgrading to our VIP warranty service options for select product categories. Please register your product and have it with you when contacting Customer Service.

SharkNinja will cover the cost for the customer to send in the unit to us for repair or replacement. A fee of \$25.95 (subject to change) will be charged when SharkNinja ships the repaired or replacement unit.

### How to initiate a warranty claim

You must call **1-888-228-5531** to initiate a warranty claim. You will need the receipt as proof of purchase. A Customer Service Specialist will provide you with return and packing instruction information.

### How state law applies

This warranty gives you specific legal rights, and you also may have other rights that vary from state to state. Some states do not permit the exclusion or limitation of incidental or consequential damages, so the above may not apply to you.

## REGISTER YOUR PURCHASE

 [registryourshark.com](http://registryourshark.com)



## RECORD THIS INFORMATION

Model Number: \_\_\_\_\_

Date of Purchase: \_\_\_\_\_  
(Keep receipt)

Store of Purchase: \_\_\_\_\_

**TIP:** You can find the model and serial numbers on the QR code labels on the bottom of the robot and base.

## EXPECTED PERFORMANCE

Expected runtime: 60 minutes  
Expected charging time: 6 hours

## PLEASE READ CAREFULLY AND KEEP FOR FUTURE REFERENCE.

This Owner's Guide is designed to help you keep your Shark Matrix™ Plus 2-In-1 Robot running at peak performance.

SharkNinja Operating LLC  
US: Needham, MA 02494  
CAN: Ville St-Laurent, QC H4S 1A7

1-888-228-5531  
[sharkclean.com](http://sharkclean.com)

Illustrations may differ from actual product. We are constantly striving to improve our products; therefore the specifications contained herein are subject to change without notice.

This product may be covered by one or more U.S. patents. See [sharkninja.com/patents](http://sharkninja.com/patents) for more information.

NOTES

NOTES

NOTES

NOTES

---

---



## FCC WARNINGS

This equipment has been tested and found to comply with the limits for a Class B digital device, pursuant to parts 15 of the FCC Rules. These limits are designed to provide reasonable protection against harmful interference in a residential installation. This equipment generates, uses, and can radiate radio frequency energy and, if not installed and accordance with the instructions, may cause harmful interference to radio communications. However, there is no guarantee that interference will not occur in a particular installation. If this equipment does cause harmful interference to radio or television reception, which can be determined by turning the equipment off and on, the user is encouraged to try to correct the interference by one or more of the following measures:

- Reorient or relocate the receiving antenna.
- Increase the separation between the equipment and receiver.
- Connect the equipment into an outlet on a circuit different from that to which the receiver is connected.
- Consult the dealer or an experienced radio/TV technician for help.

This Device complies with part 15 of the FCC rules. Operation is subject to the following conditions:

1 This device may not cause harmful interference

2 This device must accept any interference received, including interference that may cause undesired operation.

Changes or modifications not expressly approved by the party responsible for compliance could void the user's authority to operate this device.

## ISED STATEMENT

This device complies with Industry Canada license-exempt RSS standard(s). Operation is subject to the following two conditions: (1) this device may not cause interference, and (2) this device must accept any interference, including interference that may cause undesired operation of the device. Le présent appareil est conforme aux CNR d'Industrie Canada applicables aux appareils radio exempts de licence. L'exploitation est autorisée aux deux conditions suivantes : (1) l'appareil ne doit pas produire de brouillage, et (2) l'utilisateur de l'appareil doit accepter tout brouillage radio-électrique subi, même si le brouillage est susceptible d'en compromettre le fonctionnement.



## BATTERY REMOVAL AND DISPOSAL

This product uses a battery. When the battery no longer holds a charge, it should be removed from the vacuum and recycled. **DO NOT incinerate or compost the battery.**

When your lithium-ion battery needs to be replaced, dispose of it or recycle it in accordance with local ordinances or regulations. In some areas, it is illegal to place spent lithium-ion batteries in the trash or in a municipal solid waste stream. Return spent battery to an authorized recycling center or to retailer for recycling. Contact your local recycling center for information on where to drop off the spent battery.

**For more information on battery removal for disposal, please visit [sharkclean.com/batterysupport](http://sharkclean.com/batterysupport).**

The RBRC™ (Rechargeable Battery Recycling Corporation) seal on the lithium-ion battery indicates that the costs to recycle the battery at the end of its useful life have already been paid by SharkNinja. In some areas, it is illegal to place spent lithium-ion batteries in the trash or municipal solid waste stream and the RBRC program provides an environmentally conscious alternative.

RBRC, in cooperation with SharkNinja and other battery users, has established programs in the United States and Canada to facilitate the collection of spent lithium-ion batteries. Help protect our environment and conserve natural resources by returning the spent lithium-ion battery to an authorized SharkNinja service center or to your local retailer for recycling. You may also contact your local recycling center for information on where to drop off the spent battery, or call 1-800-798-7398.

© 2024 SharkNinja Operating LLC. SHARK, SHARKCLEAN, and VACMOP are registered trademarks of SharkNinja Operating LLC. AI LASER NAVIGATION and SHARK MATRIX are trademarks of SharkNinja Operating LLC. RBRC is a trademark of Rechargeable Battery Recycling Corporation. APPLE, the Apple logo, and iPhone are trademarks of Apple Inc., registered in the U.S. and other countries. APP STORE is a service mark of Apple Inc., registered in the U.S. and other countries. GOOGLE, GOOGLE ASSISTANT, GOOGLE PLAY, the Google Play logo, android are trademarks of GOOGLE LLC.



@sharkcleaning